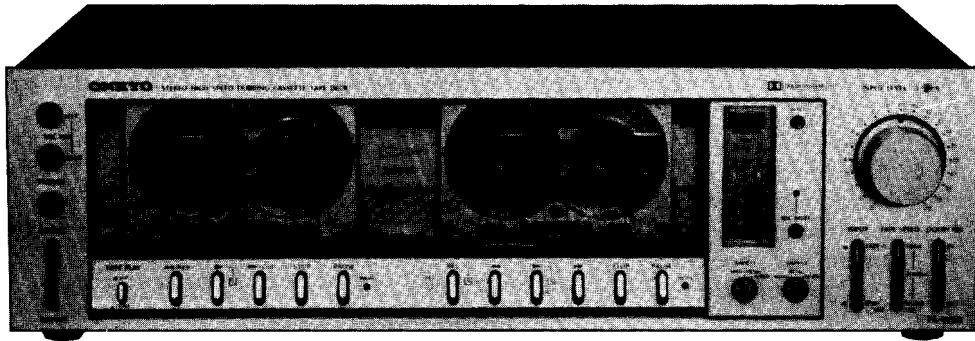

ONKYO® SERVICE MANUAL**STEREO CASSETTE
TAPE DECK
MODEL TA-W80****TABLE OF CONTENTS**

Item	Page
Specifications	2
Cautions	2
Block diagram	3
Exploded view	4
Parts list	4
Component location	5
Tape mechanism operation	6
Disassembling procedures	7
Adjustment procedures	8
Tape 1 mechanism-exploded view	11
Tape 2 mechanism-exploded view	13
Printed circuit board view from component side	15
Schematic diagram (D/Q model)	17
Printed circuit board-parts list	19
Block diagram of IC	20
Schematic diagram (G/W model)	21
Packing procedures	23

ONKYO®
AUDIO COMPONENTS

SPECIFICATIONS

Track System:	4-track, 2-channel stereo	Outputs:	Line Out: 2
Recording System:	AC bias		Output level: 350 mV (at 0 VU),
Erasing System:	AC erase		Optimum load impedance:
Tape Speed:	4.8 cm/sec. High Speed 9.5 cm/sec.		over 50 k Ω
Wow and Flutter:	0.06% (WRMS)		DIN Jack
Frequency Response:	20 – 15,000 Hz (30 – 14,000 Hz \pm 3 dB) (normal position tape)		Standard output level:
	20 – 16,000 Hz (30 – 15,000 Hz \pm 3 dB) (high position tape)		350 mV (0 VU)
	20 – 16,000 Hz (30 – 15,000 Hz \pm 3 dB) (metal position tape)		Optimum load impedance:
Signal-to-Noise Ratio:	Dolby NR out, 58 dB (metal position tape)		more than 50 k Ω
	A noise reduction of 10 dB above 5 kHz and 5 dB at 1 kHz is possible with the Dolby NR in		Headphone Jack: 1
Input Jacks:	Microphone Jacks: 2	Motor:	8 Ω – 200 Ω
	Minimum input level: 0.3 mV/600 Ω	Heads:	DC Servo motor: 2
	Input impedance: 5 k Ω		Hard permalloy heads
	Optimum mic impedance:		Ferrite head
	200 Ω – 50 k Ω	Semiconductors:	TR: 56 Diodes: 18 IC: 4
	Line In: 2		LEDs: 6
	Minimum input level: 50 mV	Power Supply:	120 V/60 Hz (D model),
	Input impedance: 50 k Ω		120/220 V 50/60 Hz (W model)
	DIN Jack: 1		220 V/50 Hz (G model),
	Minimum input level: 0.1 mV/1 k Ω		240 V/50 Hz (Q model)
	Input impedance: 1 k Ω	Power Consumption:	15 W
	(Only G/W model)	Dimensions:	418(W) x 122(H) x 270(D) mm
			16-1/2" x 4-7/8" x 10-5/8"
		Weight:	5.5 kg (12.1 lbs.)
		Accessories:	Pin-type connection cord
		Mechanism	
		1. Play Torque:	35 ~ 70 g/cm
		2. FF/REW Torque:	70 ~ 140 g/cm
		3. Back Tension:	2 ~ 4 g/cm

* Specifications and external appearance are subject to change without notice because of product improvements.

CAUTIONS

1. Do not try to forcibly remove the cassette tape from the cassette holder after power has been turned off during playback or recording. Press the stop button while power is still on before removing the cassette tape.
2. The continuous tape playback function is used to play back the cassette tape in TAPE-1 holder and then the cassette tape in TAPE-2 immediately afterward. If TAPE-2 does not operate, confirm that the tape playback switch is in the SEP. position.
3. The TA-W80 has two cassette holders so that dubbing (copying) operations can be performed without using another cassette deck. To save time, the TA-W80 also has a high-speed dubbing capability that records tapes in about half the time required by normal speed recording. Tape dubbing can only be performed from the TAPE-1 cassette holder to the TAPE-2 cassette holder. Dubbing the opposite direction is not possible.

BLOCK DIAGRAM

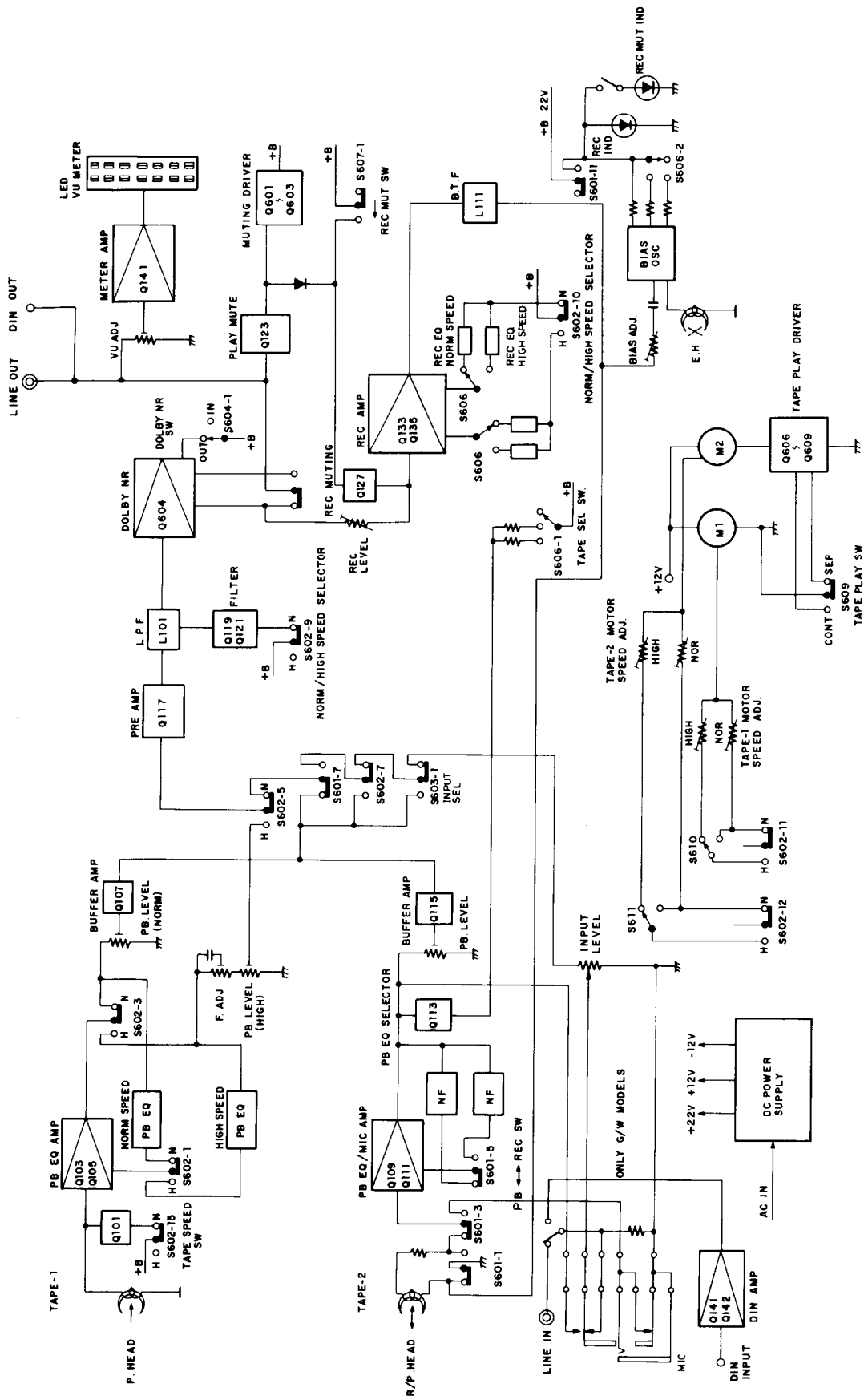

EXPLODED VIEW

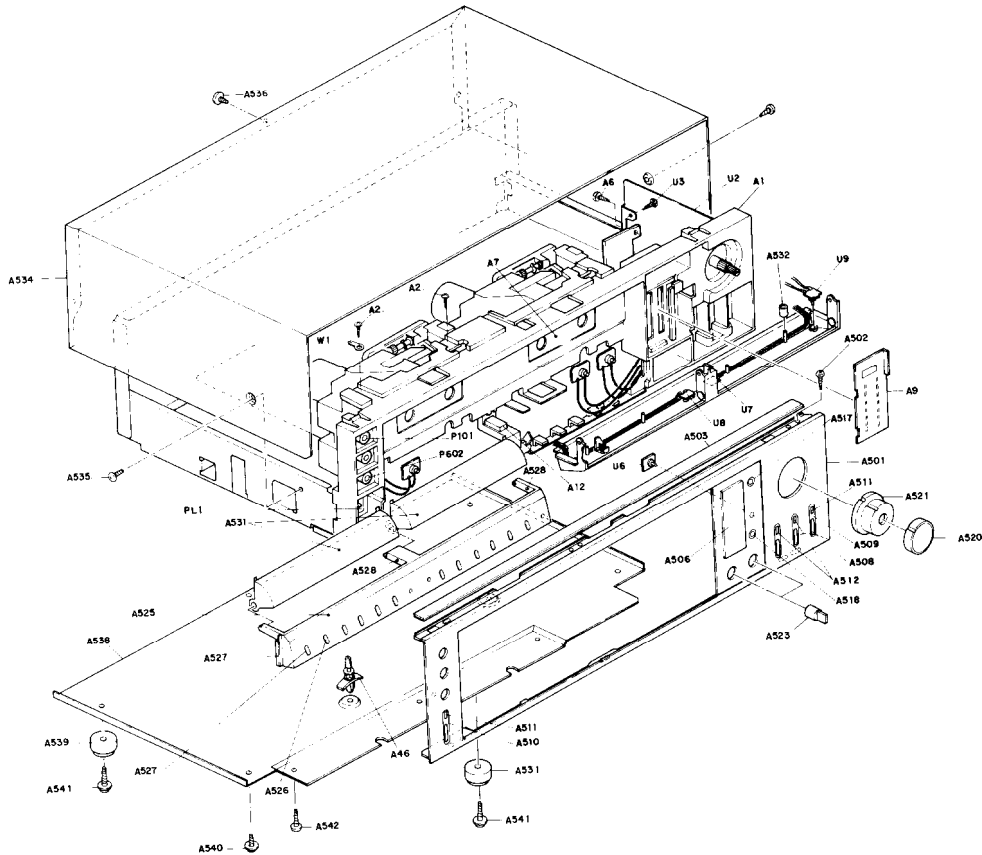

PARTS LIST

SYMBOL NO.	PARTS NO.	DESCRIPTION	SYMBOL NO.	PARTS NO.	DESCRIPTION
A1	27110130	Bracket, front	A506	28191077	Plate, clear
A2	834130102	3STS+10BQ, Tapping screw	A508	28320485	Knob, eject
A6	833130087	3TTP+8S, Tap screw	A509	27267086	Guide, push
A7	27262079	Plate		27300354	Filter
A9	28130108	Plate, dial	A510	27267087	Guide, power
A12	28140342	Cushion		27300354	Filter
A14	24601082	Counter, tape	A511	28198541A	Facet
A17	27115079A	Bracket, side	A512	28198541-1	Facet
A20	834130062	3STS+6BQ, Tapping screw	A517	27267099	Guide, meter
A22	27140479	Bracket, pc board	A518	28320519	Knob, reset/rec mute
A26	27120297	Back panel (D)	A520	28320520-1	Knob, input level, right
	27120298	Back panel (G)	A521	28320521-1	Knob, input level, left
	27120302	Back panel (W)	A523	28320516	Knob, selector
	27120319	Back panel (Q)	A525	28400027	Frame, button
A29	831130082	3STW+8BQ, Tapping screw	A526	28320483-1	Button
A31	27130245	Bracket, pc board	A527	28320522	Button, tape play
A33	270025	SR-3P4, Strainrelief (D)	A528	27270056	Spacer
	270280	SR-4K-4, Strainrelief (G/W/Q)	A530	28140344	Cushion
A35	27180022	Spring	A531	27300351	Cover, head
A36	27180076	Spring	A532	27265046	Ring, rubber
A39	27130247A	Bracket, power transformer	A534	28184091-1	Top cover
A41	833140087	4TTP+8S, Tap screw	A535	834430062	3STS+6BQ(BC), Tapping screw
A43	27260059	Shaft, switch	A536	834130082	3STS+8BQ, Tapping screw
A44	28320135	Connector	A538	27170101	Bottom board
A46	27190009	Holder	A539	27175003A	Leg
A48	831130082	3STW+8BQ, Tapping screw	A540	831130062	3STW+6BQ, Tapping screw
A50	82113006	3P+6FN, Pan head screw	A541	831130082	3STW+8BQ, Tapping screw
A51	834130062	3STS+6BQ, Tapping screw	A542	834130122	3STS+12BQ, Tapping screw
A52	27130244	Bracket	C914	3500057	0.01μF, 125V, Capacitor, CS (D)
A501	16279121	Front panel ass'y	C914	3500058	PME265M510, Capacitor, IS (G/Q)
A502	833130100	3TTP+10P, Tapping screw			
A503	28140252	Cushion	C914, C918	3500058	PME265M510, Capacitor, IS (W)

COMPONENT LOCATION

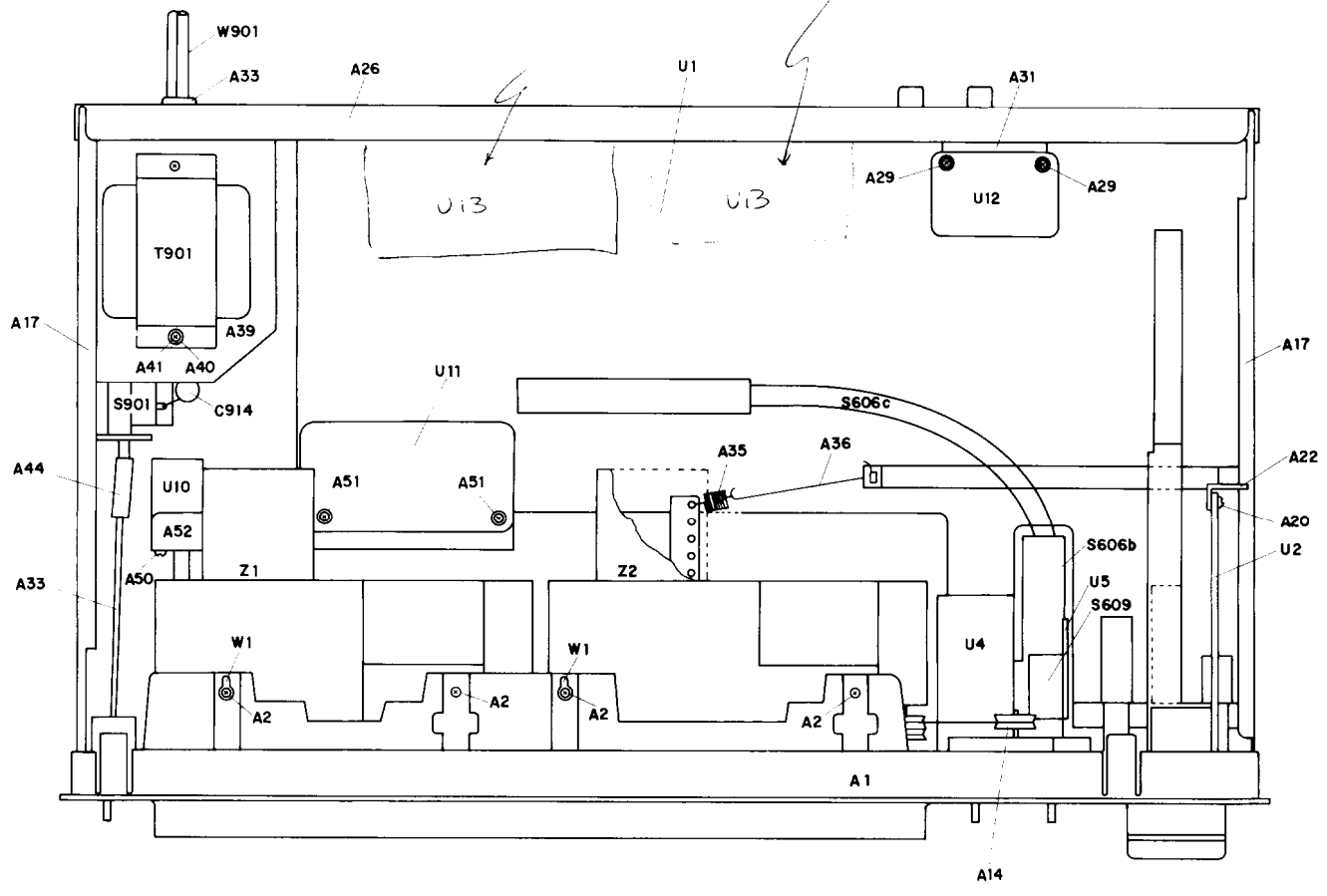

SYMBOL NO.	PARTS NO.	DESCRIPTION	SYMBOL NO.	PARTS NO.	DESCRIPTION
PL1	210083	PL14V0.06AW-3, Lamp, power	16282552A		NAVR-1052a, Volume, meter and DIN amplifier pc board ass'y (G/W)
P101, P102	25045068	HLJ-0253-01-060, Microphone jack	U3	16394553	NALED-1053, VU indicator L.E.D. pc board ass'y
P602	25045067	HLJ-0279-01-070, Stereo headphone jack	U4	16394554	NASW-1054, TAPE 1 selector switch pc board ass'y
S606b	25030184-1	NRS-103-20ZV, TAPE 2 selector switch	U5	16394555	NASW-1055, Switch pc board ass'y
S606c	25065148	Wire, switch	U6	16394556	NAPL-1056, Rec. mute. indicator pc board ass'y
S901	25035224	NPS-121-L188P, Power switch (D)	U7	16394557	NAPL-1057, Rec. indicator pc board ass'y
	25035192	NPS-122-L156P, Power switch (G/Q)	U8, U9	16394558	NAPL-1058, Pause indicator pc board ass'y
	25035207	NPS-121-L171P, Power switch (W)	U10	16394559	NASW-1059, Tape play switch pc board ass'y
S902	25065123	NSS-1258P, Voltage selector switch (W)	U11	16394560	NASC-1060, Speed control pc board ass'y
T901	230496	NPT-741D, Power transformer (D)	U12	16394588	NAMU-1088, Muting circuit pc board ass'y
	230497	NPT-741G, Power transformer (G)	W1	223004	Terminal
	230498	NPT-741DG, Power transformer (W)	W901	253099A	AS-UC-3, Power supply cable (D)
	230513	NPT-741Q, Power transformer (Q)		253083	AS-CEE, Power supply cable (G/W)
U1	16279551B	NAAF-1051b, Recording and playback amplifier pc board ass'y (D/Q)		253104	Power supply cable (Q)
	16282551A	NAAF-1051a, Recording and playback amplifier pc board ass'y (G/W)	Z1	260208	Binder
U2	16394552	NAVR-1052, Volume and meter circuit pc board ass'y (D/Q)	Z2	244023	NDM-18, Tape 1 ass'y
				244022-1	NDM-17, Tape 2 ass'y ✓

Note:
 (D): Only 120V model (W): Only 120/220V model
 (G): Only 220V model (Q): Only 240V model

TAPE MECHANISM OPERATION

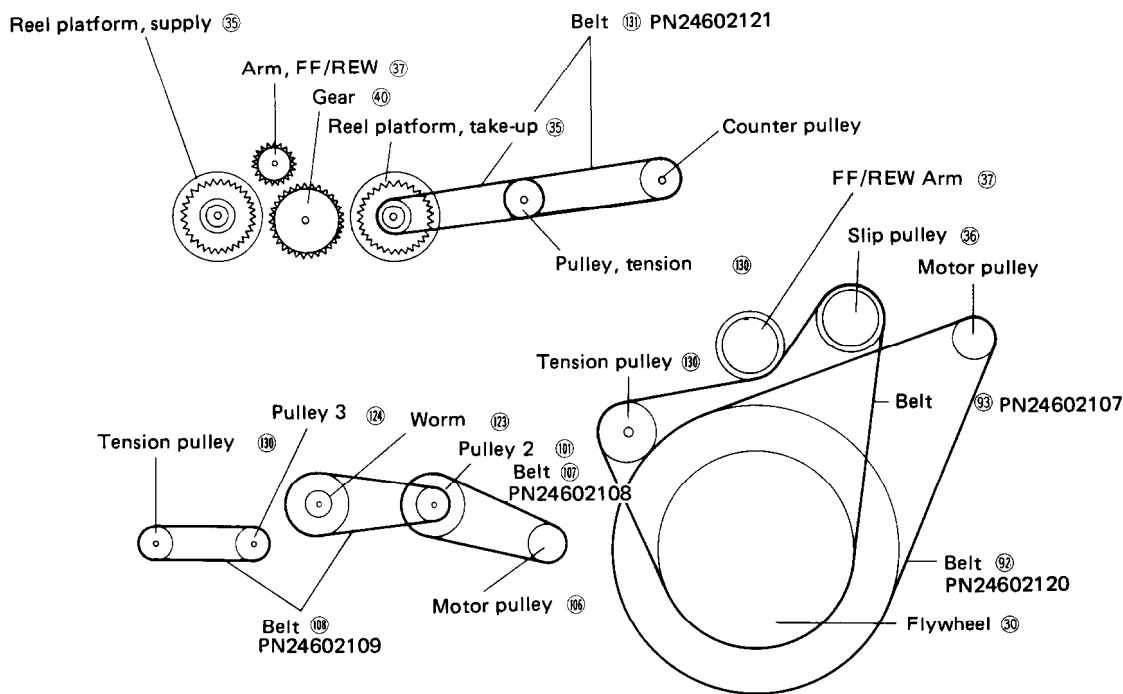

PLAY operation

When the play key is pressed, the trigger arm (25) of the trigger lever (110) unlocks the operation gear (24) and the flywheel gear (31) and operation gear (24) engage. The driving force from the motor is transmitted through the flywheel gear to drive the operating gear. The operating gear camshaft pulls the operating plate (17) up and, at the same time, the head chassis 1 ass'y (2) is pulled up by the operating plate. The head chassis is then locked in place by the locking plate (70). The operating plate returns to its original position as the operating gear makes one complete revolution to be ready for the next operation. At the same time, the head chassis 1 ass'y (2) is moved, the slip pulley (36) comes in contact with the take-up reel table (35) and tape is wound.

FF operation

When the fast forward key is pressed, the trigger arm of the trigger lever unlocks the operating gear and the flywheel gear and operating gear engage. The operating gear camshaft pulls the operating plate up to move the FF lever. The gear (40) comes in contact with the FF, REW arm ass'y (37) and the take-up reel table and tape is wound.

REW operation

When the rewind key is pressed, the trigger arm of the trigger lever unlocks the operating gear and the flywheel gear and operating gear engage. The operating gear camshaft pulls the operating plate up to raise the REW lever which is then locked in place by the locking plate (70). At the same time, the REW lever causes the FF, REW arm ass'y gear and take-up reel table (35) to come in contact and tape is wound.

PAUSE operation

When the pause key is pressed, the trigger lever, trigger arm (25) and operating gear (24) are activated in that order and the operating plate (17) is raised. At the same time, the operating plate pulls up the pause lever (58) which moves the slip pulley ass'y (36) so that it is disengaged from the reel table. The pause lever is locked in place by the pause camshaft (61).

Auto-stop operation

When the end of the tape is reached, the reel table stops moving and the auto-stop ass'y slider section also stops moving. At the camshaft (126) when the stop lever 2 (90) is pressed via the slider, the trigger camshaft (25), operating gear (24), operating plate (17), and stop lever (54) are activated in that order to cause the locking plate (70) to slide and release the stop key.

Circled part numbers are disassembly diagram numbers.

DISASSEMBLING PROCEDURES

1. Top cover and front panel

- Remove the three screws (A536) holding the top cover and back panel.
- Remove the two screws (A535) holding the top cover and side brackets.
- Remove the cushion (A503) on the front panel.
- Remove the six screws (A502) holding the front panel and front bracket.

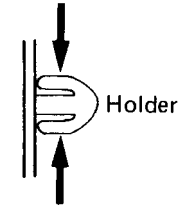

(fig. 4)

2. Bottom board

- Remove the four screws (A540) holding the bottom board and side brackets.
- Remove the two screws (A541) holding the bottom board and legs.
- Remove the four screws (A542) holding the bottom board and front bracket.
- Remove the two holders from bottom board by pressing against the holder from both sides. (see fig. 4)

3. Cassette button panel

- Remove the top cover and front panel.
- Insert the screw driver between (A) as shown fig. 5 and remove the cassette button panel from front bracket by pressing the position (B).

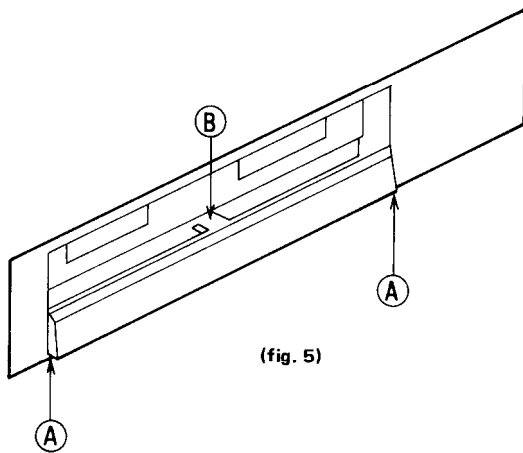

(fig. 5)

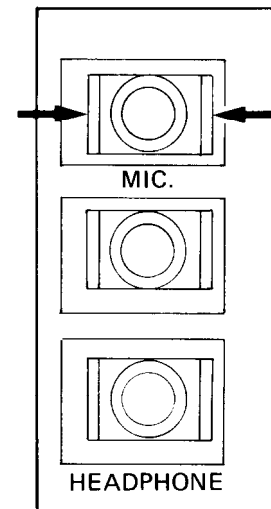

(fig. 6)

4. Cassette mechanism of TAPE-2 (right side)

- Remove the top cover, front panel, and bottom board.
- Remove the three screws (A2) holding the front bracket and cassette mechanism.

5. Cassette mechanism of TAPE-1 (left side)

- 1) Remove the top cover, front panel and bottom board.
- 2) Remove a screw holding the front bracket and input selector switch.
- 3) Remove a screw holding the volume control pc board and pc bracket from right side.
- 4) Remove the headphone jack and two mic. jacks by pressing against from both sides. (see fig. 6)
- 5) Remove two screws holding the muting pc board and pc bracket.
- 6) Remove three screws holding tape mechanism and front bracket.

ADJUSTMENT PROCEDURES

PRECAUTIONS

- Before adjustment, clean the following parts with an alcohol moistend swab.
 - * record/playback head
 - * pinch roller
 - * rubber belt
 - * erase head
 - * capstan
- Do not use magnetized screwdriver for adjustments.
- Damagnetize record/playback head with a head demagnetizer.
- The switches and controls should be set as follows unless otherwise specified.

TAPE SEL. 1& 2	NORM
DOLBY NR	OUT
TAPE SPEED	NORM
INPUT SELECTOR	MAX
INPUT LEVEL	0
- TAPE 1 ... left side, TAPE 2 ... right side

1. Head azimuth adjustment

- Play the VTT-658 test tape back.
- Adjust the head azimuth screw so that the phase relationship between L- and R-channels approximates 0 degrees as indicated on the oscilloscope.
- At this time confirm that playback output level is approximately the maximum value on the AC voltmeter.
- Then confirm that the phase difference of the respective frequency is with in the rated value. 90 degrees or less in the range of 40Hz to 10kHz is required.
- Secure the screw with the locking paint.

Note: This adjustment should be performed for both TAPE 1 and TAPE 2.

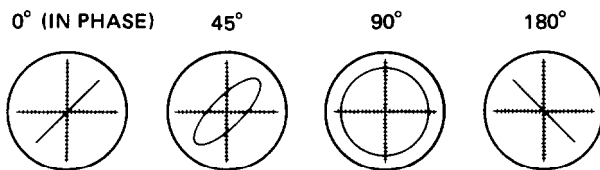
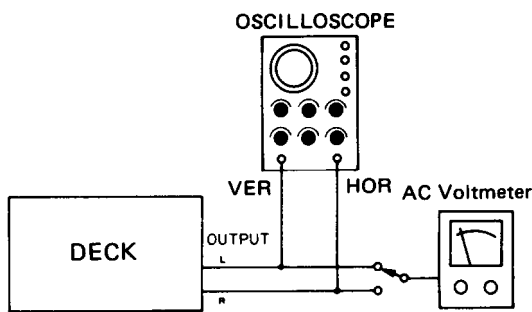

Confirming phase relationship

TEST EQUIPMENT/TOOLS REQUIRED:

- Audio oscillator
- Digital frequency counter
- Oscilloscope
- Attenuator
- AC voltmeter
- Non-magnetic screw driver, shorted clip
- Blank tapes (completely erased)
 - NORMAL UD-XL/I
 - HIGH UD-XL/II
 - METAL MX
- Test tapes
 - VTT-658 : 10kHz, -15dB
 - MTT-111 : 3kHz, -10dB
 - MTT-150 : Dolby level calibration
400Hz tone 200 nWb/m
 - MTT-215C : 315Hz, 10kHz, -10dB

2. Tape speed adjustment

Normal speed

Insert the MTT-111 test tape into the TAPE-1 cassette holder. Play the MTT-111 back. Adjust the R631 semi-fixed resistor so that the counter indication becomes 3,000Hz to 3,010Hz. Next insert the MTT-111 test tape into the TAPE-2 cassette holder. Play the MTT-111 back. Adjust the R635 semi-fixed resistor so that the indications of TAPE-1 and TAPE-2 become the same frequency.

High speed

Insert the MTT-111 test tape into the TAPE-1 cassette holder. Set the tape speed switch to the HIGH position. Play the MTT-111 back. Adjust the R633 semi-fixed resistor so that the counter indication becomes 6,000Hz to 6,010Hz. Next insert the MTT-111 into the TAPE-2 cassette holder. Connect the shorted clip between TP-1 and TP-2 terminals. Play the MTT-111 back. Adjust the R637 semi-fixed resistor so that the indications of TAPE-1 and TAPE-2 become the same frequency.

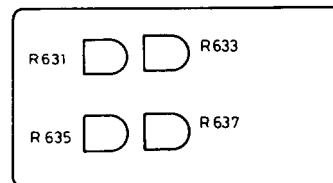
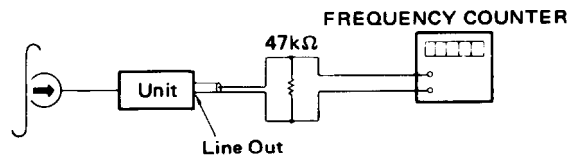

NASC-1060

- R631 ... TAPE 1 Normal speed adjustment
- R633 ... TAPE 1 High speed adjustment
- R635 ... TAPE 2 Normal speed adjustment
- R637 ... TAPE 2 High speed adjustment

3. Playback level adjustment

Normal speed

Insert the MTT-150 test tape into the TAPE-1 cassette holder. Play the MTT-150 back. Adjust the R283 (L ch.) and R284 (R ch.) semi-fixed resistors so that the indication of voltmeter becomes 825mV.

Next the MTT-150 into the TAPE-2. Play the MTT-150 back. Adjust the R121 (L ch.) and R122 (R ch.) semi-fixed resistors so that the indication of voltmeter becomes 775mV.

High speed

Set the tape speed switch to the HIGH position. Insert the MTT-150 into the TAPE-1 cassette holder. Play the MTT-150 back. Adjust the R129 (L ch.) and R130 (R ch.) semi-fixed resistors so that the indication of voltmeter becomes 825mV.

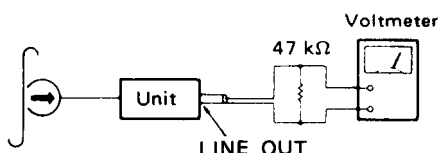

4. VU indication adjustment

Insert the MTT-150 test tape into the TAPE-2 cassette holder. Play the MTT-150 back. Adjust the R283 (L ch.) and R284 (R ch.) semi-fixed resistors so that the +3dB L.E.D. of VU indication lights up. Next apply the 1kHz signal to the line-in terminals. Press the pause and recording buttons and put the TAPE-2 into the recording mode. Adjust the input level volume so that the 0dB L.E.D. of VU indication light up. Then set the attenuator for -1dB input level. Adjust the R283 and R284 so that the 0dB L.E.D. goes out. Confirm that the +3dB L.E.D. light up when play the MTT-150 back.

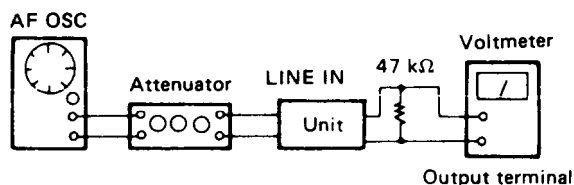

5. Playback frequency adjustment

Set the tape speed switch to the HIGH position. Insert the MTT-215C test tape into the TAPE-1 cassette holder. Adjust the R131 (L ch.) and R132 (R ch.) semi-fixed resistors so that the 315Hz and 10kHz signals become same level.

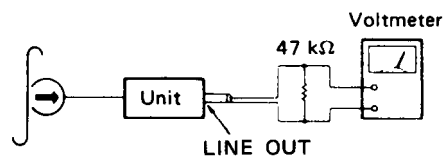

6. Recording bias adjustment

Insert the normal blank tape into the TAPE-2 cassette holder.

Press the recording and pause buttons and put the TAPE-2 into the recording mode.

Apply the 400Hz signal to line-in terminal. Adjust the input level volume so that the 0dB indicator light up. Then set the attenuator for -20dB input level. Release the pause button and record on the tape. Next change the frequency of the 10kHz and record again.

Adjust the R295 (L ch.) and R296 (R ch.) so that the 400Hz and 10kHz playback levels become same.

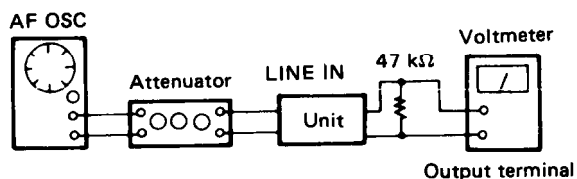

7. Recording level adjustment

Insert the normal blank tape into the TAPE-2 cassette holder. Apply the 1,000Hz signal to line-in terminal. Put the TAPE-2 into the recording mode. Adjust the input level volume so that the voltmeter reads 350mV. Record on the tape. Adjust the R225 (L ch.) and R226 (R ch.) so that the playback level becomes 350mV ±0.5dB.

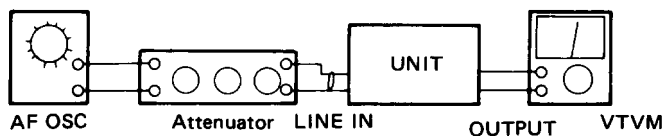

8. Auto-stop adjustment

While confirming that auto-stop is operating properly, turn the adjustment screw to obtain stable auto-stop operation. When the stroke of the stop lever is too small, turn the adjustment screw clockwise. If the stop lever is so heavy that it can not be depressed by the worm gear when the stop lever is pressed by the slider, turn the adjustment screw counterclockwise.

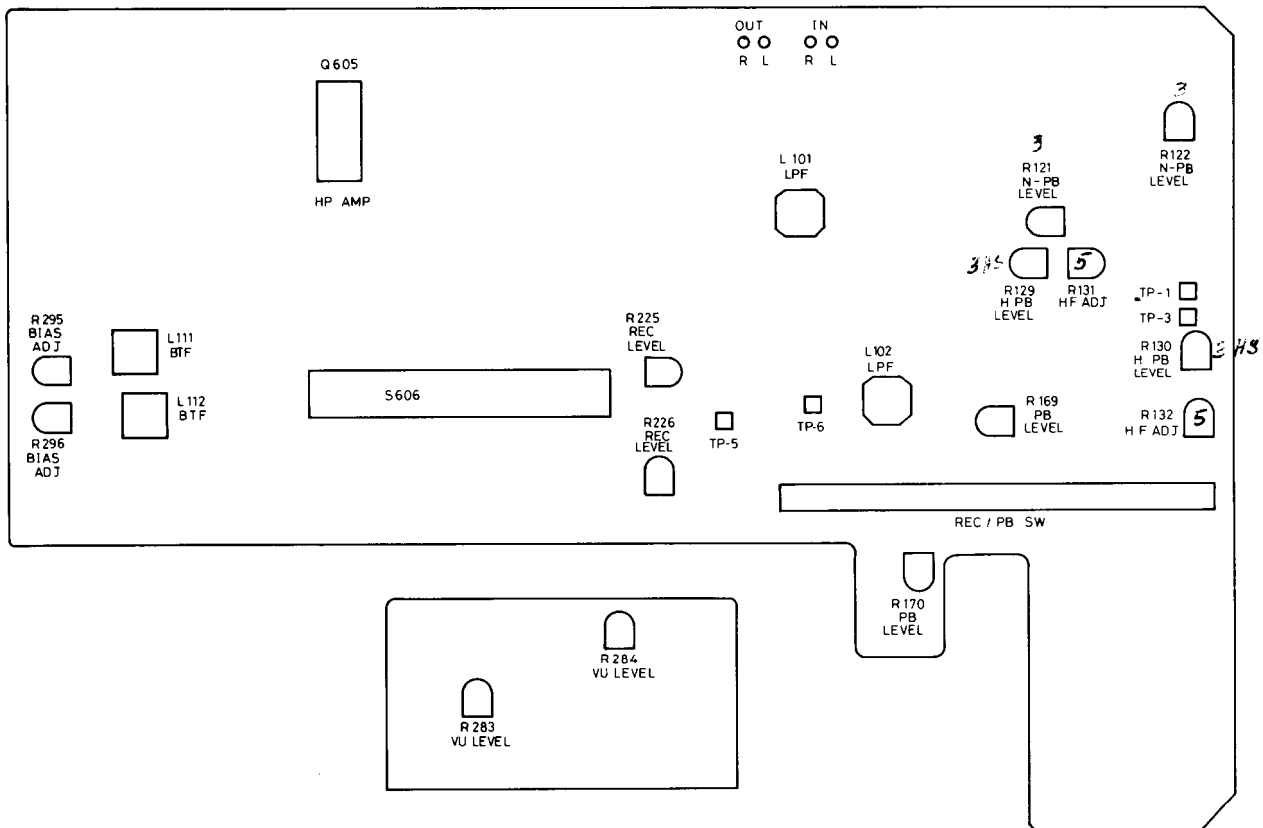
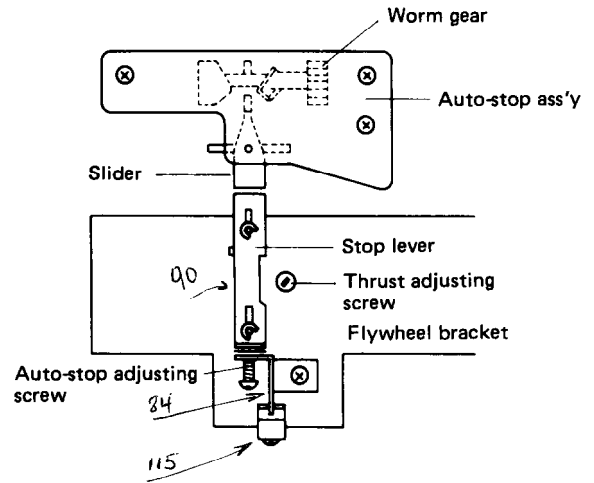

TAPE 1 MECHANISM – EXPLODED VIEW

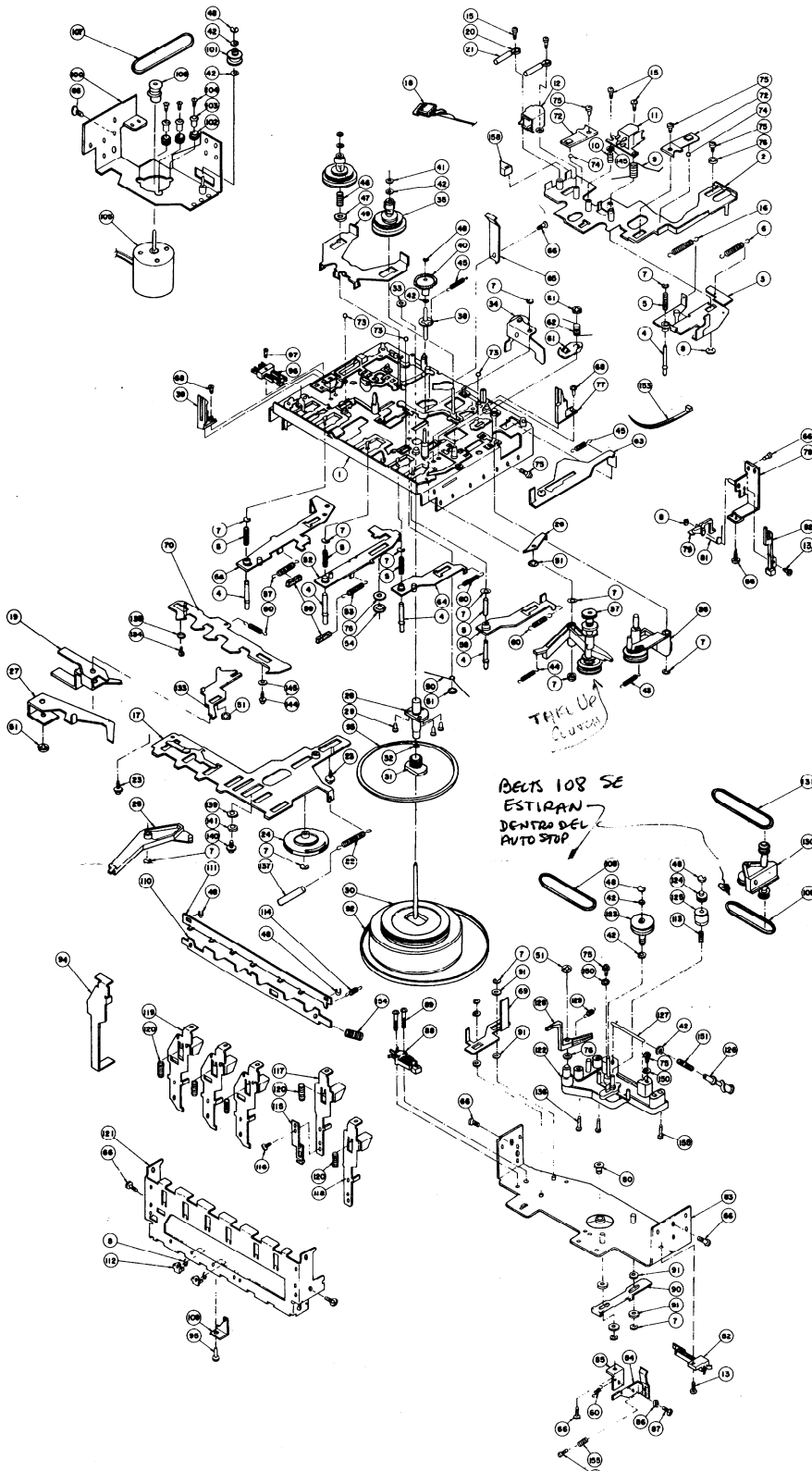

REF. NO.	PARTS NO.	DESCRIPTION
31	24602104	Flywheel gear
32	24610564	PSW2.5x4.7x0.25, Washer
33	24610567	2.4x8x0.3, Washer, Nylon
34	24610617	Pinch roller
35	24602105	Reel stand
36	24602113	Slip pulley
37	24610533	FF/REW arm
38	24610534	Slider
39	24610535	Holder (L)
40	24602112	Gear
41	24610565	PSW1.6x3.2x0.25, Washer
42	24610566	PSW2x4x0.25, Washer
43	24605254	Spring for 36
44	24605255	Spring for 37
45	24605256	Spring
46	24605257	Spring for back tension
47	24610569	NW4x10x0.5, Washer
48	893015	E-1.5, Circlip
49	24610618	Brake plate
50	24605271	Spring for brake
51	891030	CS3, CS ring
52	24603197	FF lever ass'y
53	24605282	Spring for 52
54	8761401005	FW4x10x0.5, Washer
55	891040	CS4, CS ring
56	24603166	Rewind lever
57	24605288	Spring for 56
58	24603167	Pause lever
59	24610580	Cushion
60	24605261	Spring
61	24610593	Pause cam
62	24605262	Spring for 61
63	24603198	Pause lever 2
64	24603169	Stop lever
65	24605285	Cassette holding spring
66	833130059	CT3x5, Screw
68	801235	2.6x3, Screw
69	24603183	Switch lever
70	24610541	Locking plate
71	82112606	FM+2.6x6, Screw
72	24605265	Spring for head chassis holding
73	24610542	3 φ, Steelball
74	24610543	2 φ, Steelball
75	831126042	TPT+2.6x4, Screw
76	8761420704	FW4.2x7x0.4, Washer
77	24610536	Holder (R)
78	24610544	Switch bracket 1
79	24603171	Lever 1
80	24610571	Thrust adjusting screw
81	24605279	Spring for 79
82	24603178	Leafswitch
83	24610586	Flywheel bracket
84	24603172	Stop lever 1
85	24610546	Bracket
86	24610583	Spacer
87	833126059	CT2.6x5, Screw
88	24603184	Skeleton switch
89	82112008	FM+2x8, Screw
90	24603174	Stop lever 2
91	24610588	NW3.2x8x0.3, Washer
92	24602120	Belt
93	24602107	Belt
94	24610587	Operation button
95	833130089	CT3x8, Screw
96	24603196	Leafswitch
97	82112010	FM+2x10, Screw
98	801183	(T)-2x4, Screw
100	24610582	Motor bracket
101	24602115	Pulley 2
102	24610550	Motor cushion
103	24604040	Pipe
104	801178	2.6x8, Sems screw
105	24601089-1	Motor ass'y
106	24601097	Motor pulley
	801183	2x4, Screw for pulley
107	24602108	Belt
108	24602109	Belt
109	24610551	Bracket for spring
110	24610552	Trigger cam
111	24610553	Locking plate
112	24610554	Seesaw cam
113	24605290	Spring for 125
114	24605281	Spring for 111
115	24603175	Lever
116	82113003	FM+3x3, Screw
117	24610555	Operation lever 3
118	24610556	Operation lever 2
119	24610557	Operation lever 1
120	24605269	Spring
121	24610621	Operation lever bracket
122	24610559	Bracket
123	24602117	Worm
124	24602116	Pulley 3
125	24610560	Guide
126	24610561	Cam
127	24604041	Shaft
128	24603176	Lever 2
129	24605270	Spring for 128
130	24610562	Tension pulley bracket
131	24602121	Belt
133	24603177	Switch lever 1
134	82112608	FM+2.6x8, Screw
135	24610583	Spacer
136	82113014	FM+3x14, Screw
137		Tube
138	82112004	FM+2x4, Screw
139	24610577	Felt
140	831130082	TPT3x8, Screw
141	8761321205	FW3.2x12x0.5, Washer
144	833126052	TP2.6x5, Screw
145	8761260805	FW2.6x7.5x0.5, Washer
150	876130803	FW3x8x0.3, Washer
151	24605273	Spring for 126
153	260208	Binder
154	24605291	Spring for 110
155	24503088	Spring for 84
157	24610624	Switch bracket
158	24610625	Switch chip
159	82113015	FM+3x15, Screw

REF. NO.	PARTS NO.	DESCRIPTION
1	24610522	Chassis
2	24610615	Head chassis 1
3	24610616	Head chassis 2
4	24604042	Shaft
5	24605248	Spring for 4
6	24605289	Spring for 3
7	893020	E-2, Circlip
8	893030	E-3, Circlip
9	24605250	Spring
10	24605284	Head azimuth adjusting spring
11	24600028	Rec/pb head
12	24600029	Dummy head
15	801237	2x6mm, Screw
16	24605286	Spring for 3

REF. NO.	PARTS NO.	DESCRIPTION
17	24610622	Actuating plate
18	25050088	Rec/pb connector
19	24603194	Selector lever 1
20	24610623	Terminal
21		Tube
22	24605277	Spring for 17
23	831130062	TPT+3x6mm, Screw
24	24602111	Gear
25	24610528	Trigger arm
26	24610529	Canceller arm
27	24603181	Selector lever 2
28	24610531	Flywheel holder
29	82112604	FM+2.6x4, Screw
30	24602103	Flywheel

TAM80

TAPE 2 MACHINISM-EXPLODED VIEW

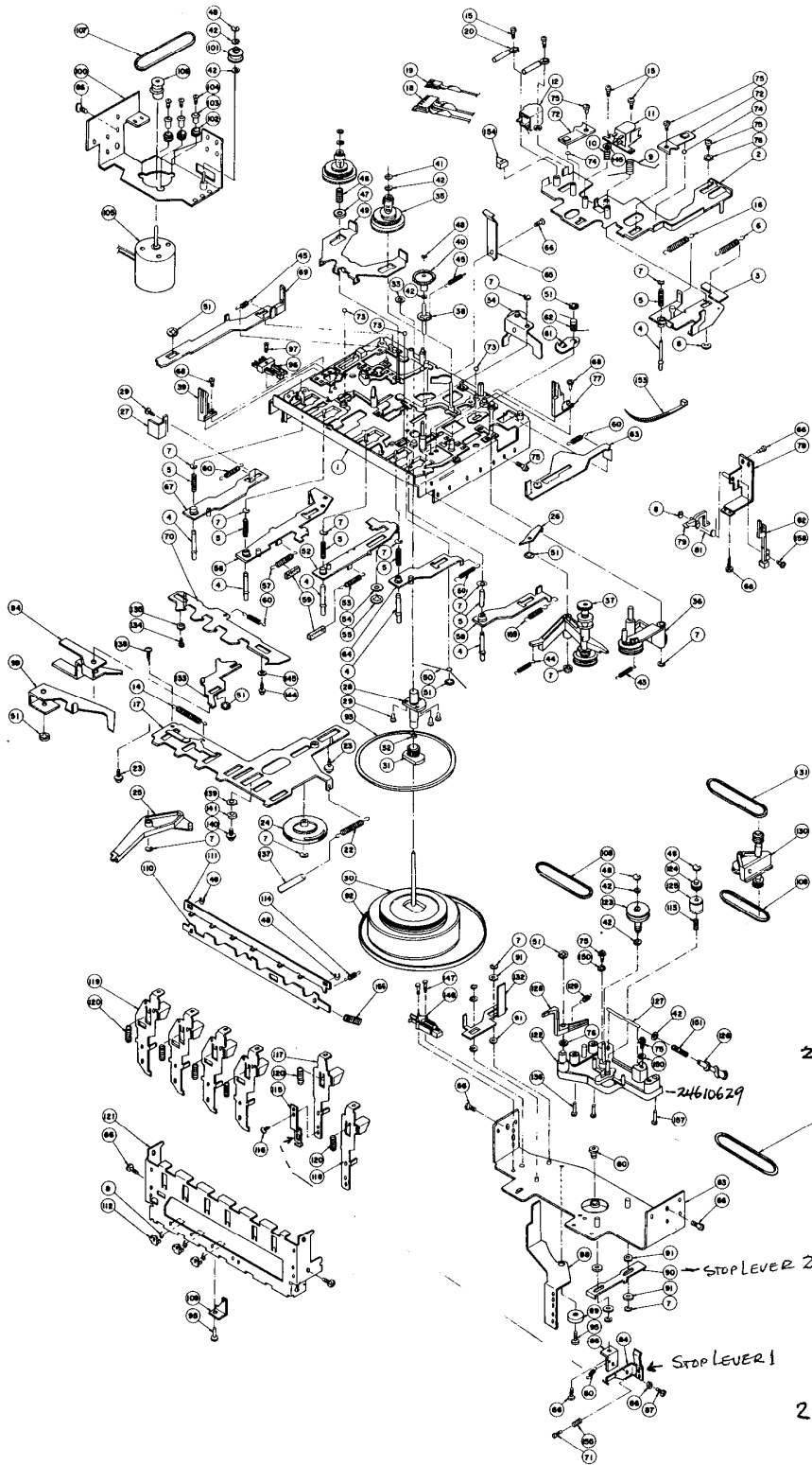

REF. NO.	PARTS NO.	DESCRIPTION
37	24610533	FF/REW arm
38	24610534	Slider
39	24610535-1	Holder (L)
40	24602112	Gear
41	24610565	PSW1.6x3.2x0.25, Washer
42	24610566	PSW2x4x0.25, Washer
43	24605254	Spring for 36
44	24605255	Spring for 37
45	24605256	Spring
46	24605257	Spring for back tension
47	24610569	NW4x10x0.5, Washer
48	893015	E-1.5, Circlip
49	24610618	Brake plate
50	24605271	Spring for brake
51	891030	CS3, CS ring
52	24603197	FF lever ass'y
53	24605282	Spring for 52
54	8761401005	FW4x10x0.5, Washer
55	891040	CS4, CS ring
56	24603166	Rewind lever
57	24605288	Spring for 56
58	24603167	Pause lever
59	24610580	Cushion
60	24605261	Spring
61	24610593	Pause cam
62	24605262	Spring for 61
63	24603198	Pause lever 2
64	24603169	Stop lever
65	24605286	Cassette holding spring
66	833130059	CT3x5, Screw
67	24603170	Recording lever 1
68	801235	2.6x3, Screw
69	24610540	Lever
70	24610541	Locking plate
71	82112606	FM+2.6x6, Screw
72	24605265	Spring
73	24610542	3φ, Steelball
74	24610543	2φ, Steelball
75	831126042	TPT+2.6x4, Screw
76	8761420704	FW4.2x7x0.4, Washer
77	24610536-1	Holder (R)
78	24610544	Switch bracket 1
79	24603171	Lever 1
80	24610571	Thrust adjusting screw
81	24605279	Spring for 79
82	24603178	Leafswitch
83	24610586	Flywheel bracket
84	24603172	Stop lever 1
85	24610546	Bracket
86	87613008	Spacer
87	833126059	CT2.6x5, Screw
88	24603173	Recording lever
89	24610572	Spacer
90	24603174	Stop lever 2
91	24610588	NW3.2x8x0.3, Washer
92	24602120	Belt
93	24602107	Belt
94	24603194	Selector lever
95	833130089	CT3x8, Screw
96	24603196	Leafswitch
97	82112010	FM+2x10, Screw
99	24603181	Selector lever 2
100	24610582	Motor bracket
101	24602115	Pulley 2
102	24610550	Motor cushion
103	24604040	Pipe
104	801178	2.6x8, Sems screw
105	24601089-1	Motor ass'y
106	24601097	Motor pulley
	801183	2x4, Screw for pulley
107	24602108	Belt
108	24602109	Belt
109	24610551	Bracket for spring
110	24610552	Trigger cam
111	24610553	Locking plate
112	24610554	Seesaw cam
113	24605290	Spring
114	24605281	Spring
115	24603175	Lever
116	82113003	FM+3x3, Screw
117	24610555	Operation lever 3
118	24610556	Operation lever 2
119	24610557	Operation lever 1
120	24605269	Spring
121	24610621	Operation lever bracket
122	24610628	Bracket
123	24602117	Worm
124	24602116	Pulley 3
125	24610560	Guide
126	24610561	Cam
127	24604041	Shaft
128	24603176	Lever 2
129	24605270	Spring
130	24610562	Tension pulley bracket
131	24602121	Belt
132	24603183	Switch lever
133	24603177	Switch lever 1
134	82112608	FM+2.6x8, Screw
135	24610583	Spacer
136	821130169	FM+3x16, Screw
137		Tube
138	82112004	FM+2x4, Screw
139	24610577	Felt
140	831130082	TPT3x8, Screw
141	8761321308	FW3.2x13x0.8, Washer
144	833126052	TP2.6x5, Screw
145	8761260805	FW2.6x7.5x0.5, Washer
147	82112008	FM+2x8, Screw
148	24603184	Skeleton switch
150	8761300803	FW3x8x0.3, Washer
151	24605273	Spring for 126
152		Tube
153	260208	Binder
154	24610625	Switch chip
155	24503088	Spring for 84
156	24605291	Spring for 110
157	82113015	FM+3x15, Screw
158	833126069	CT2.6x6, Screw
159	24605295	Spring

REF. NO.	PARTS NO.	DESCRIPTION
1	24610522	Chassis
2	24610615	Head chassis 1
3	24610616	Head chassis 2
4	24604042	Shaft
5	24605248	Spring for 4
6	24605289	Spring for 3
7	893020	E-2, Circlip
8	893030	E-3, Circlip
9	24605250	Spring
10	24605284	Head azimuth adjusting spring
11	24600028	Rec/pb head
12	24600015	Erase head
14	24605270	Spring for 17
15	801237	2x6mm, Screw
16	24605286	Spring for 3
17	24610622	Actuating plate
18	25050091	Rec/pb connector

REF. NO.	PARTS NO.	DESCRIPTION
19	25050089	Erase connector
20	24610623	Terminal
22	24605277	Spring for 17
23	831130062	TPT+3x6mm, Screw
24	24602111	Gear
25	24610528	Trigger arm
26	24610529	Canceller arm
27	24610530	Recording arm
28	24610531	Flywheel holder
29	82112604	FM+2.6x4, Screw
30	24602103	Flywheel
31	24602104	Flywheel gear
32	24610564	PSW2.5x.47x0.25, Washer
33	24610567	2.4x8x0.3, Washer, Nylon
34	24610617	Pinch roller
35	24602127	Reel stand
36	24602126	Slip pulley

SCHEMATIC DIAGRAM D/Q model

lever

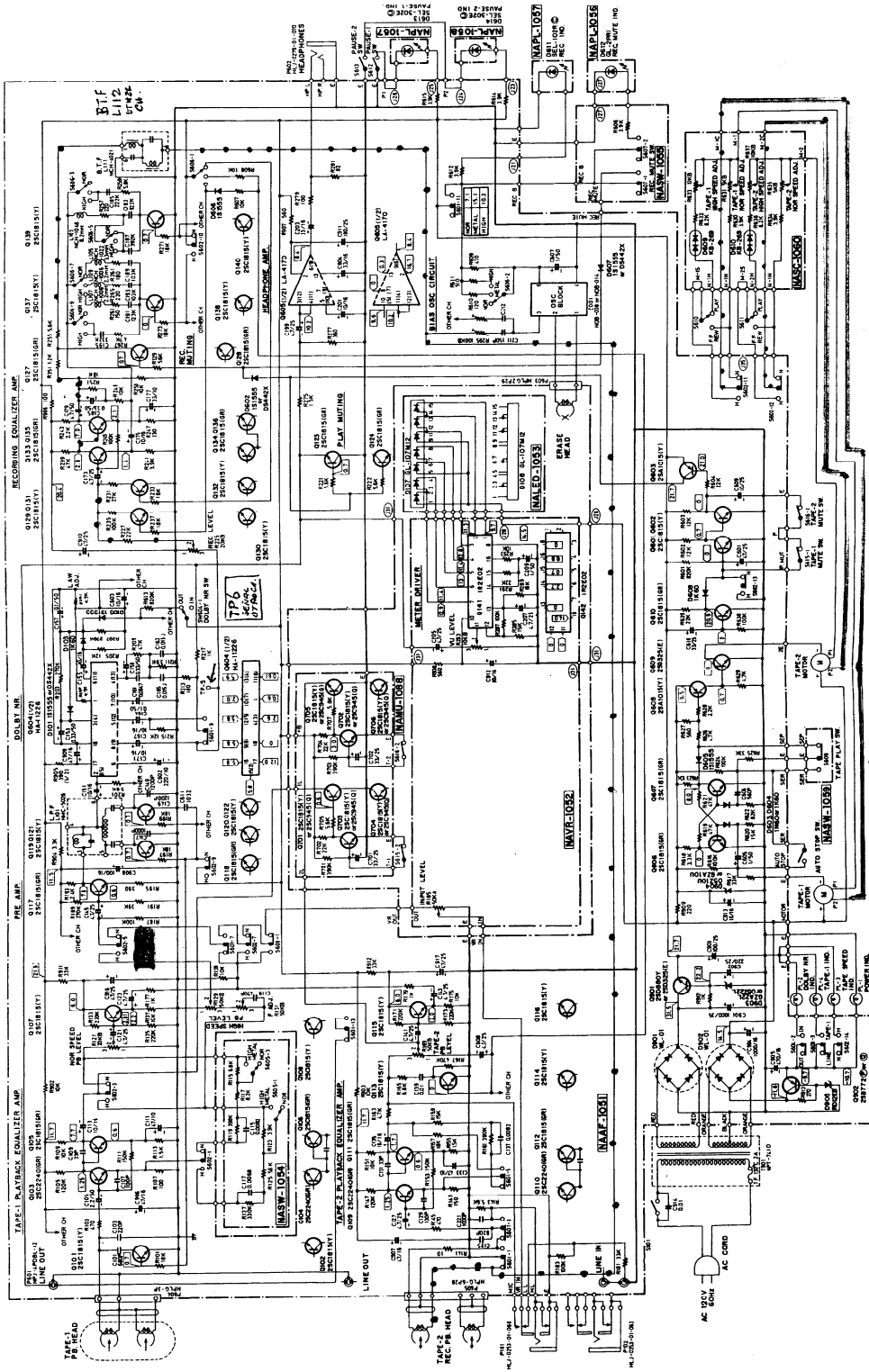

- NOTE:
1. ALL RESISTORS ARE IN OHMS, μ WATT UNLESS OTHERWISE NOTED.
 2. ALL CAPACITORS ARE IN μ F, 500V UNLESS OTHERWISE NOTED.
 3. ELECTROLYTIC CAPACITORS ARE IN μ F/MV.
 4. VOLTAGE IS MEASURED WITH V.T.V.M.
 5. CIRCUIT IS SUBJECT TO CHANGE FOR IMPROVEMENT.

ONKYO CORPORATION

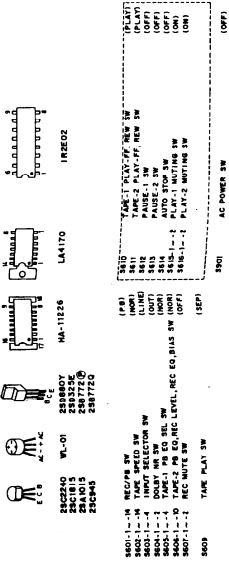

- RESISTOR VALUES
- W-01 289900
 - W-02 289900
 - W-03 289720
 - W-04 289720
 - W-05 289720
 - W-06 289720
 - W-07 289720
 - W-08 289720
 - W-09 289720
 - W-10 289720
 - W-11 289720
 - W-12 289720
 - W-13 289720
 - W-14 289720
 - W-15 289720
 - W-16 289720
 - W-17 289720
 - W-18 289720
 - W-19 289720
 - W-20 289720
 - W-21 289720
 - W-22 289720
 - W-23 289720
 - W-24 289720
 - W-25 289720
 - W-26 289720
 - W-27 289720
 - W-28 289720
 - W-29 289720
 - W-30 289720
 - W-31 289720
 - W-32 289720
 - W-33 289720
 - W-34 289720
 - W-35 289720
 - W-36 289720
 - W-37 289720
 - W-38 289720
 - W-39 289720
 - W-40 289720
 - W-41 289720
 - W-42 289720
 - W-43 289720
 - W-44 289720
 - W-45 289720
 - W-46 289720
 - W-47 289720
 - W-48 289720
 - W-49 289720
 - W-50 289720
- CAPACITOR VALUES
- C914 0.01
 - C915 0.01
 - C916 0.01
 - C917 0.01
 - C918 0.01
 - C919 0.01
 - C920 0.01

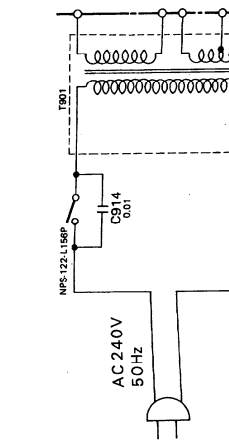

INPUT LEVEL AND VU METER DRIVER PC BOARD (NAVR-1052) – PARTS LIST
D/Q model

CIRCUIT NO.	PARTS NO.	DESCRIPTION
ICs		
Q141, Q142	222623	IR-2E02, VU driver
Resistors		
R185, R186	5104115	N16RKM50KA35F, Input level N08HR10KBA, Semi-fixed, VU level
R283, R284	5215010	
Capacitors, elect.		
C205–C208	352750479	4.7 μ F, 25V
C209, C210	352780109	1 μ F, 50V
C912, C915	352741009	10 μ F, 16V

G/W model

CIRCUIT NO.	PARTS NO.	DESCRIPTION
ICs		
Q141, Q142	222623	IR-2E02, VU driver
Transistors		
Q145, Q146	2211405	2SC2240(GR)
Resistors		
R185, R186	5104115	N16RKM50KA35F, Input level N08HR10KBA, Semi-fixed, VU level
R283, R284	5215010	
Capacitors, elect.		
C205–C208	352750479	4.7 μ F, 25V
C209, C210	352780109	1 μ F, 50V
C215–C218	352780109	1 μ F, 50V
C912, C915	352741009	10 μ F, 16V

INDICATOR PC BOARDS (NALED-1053, NAPL-1056/57/58) – PARTS LIST

CIRCUIT NO.	PARTS NO.	DESCRIPTION
D107, D108	225071	GL-107M12, Diode array
D612	225018	GL2PR1, L.E.D.
D611	225074	SEL-102(R) (C), L.E.D.
D613, D614	225079	SEL-302E(C), L.E.D.

SWITCH PC BOARDS (NASW-1054/55/59) – PARTS LIST

CIRCUIT NO.	PARTS NO.	DESCRIPTION
S605	25030183	NRS-242-20U, Rotary switch, Tape 1
S607	25035244	NPS-122-S208, Push switch, Recording muting
S609	25035248	NPS-122-L212, Push switch, Tape play

SPEED CONTROL PC BOARD (NASC-1060) – PARTS LIST

CIRCUIT NO.	PARTS NO.	DESCRIPTION
R631	5215044	N08HR5KBC, Semi-fixed resistor, normal speed
R633	5215045	N08HR10KBC, Semi-fixed resistor, high speed
R635	5215044	N08HR5KBC, Semi-fixed resistor, normal speed
R637	5215045	N08HR10KBC, Semi-fixed resistor, high speed
D609, D610	4000001	KB269, Varistor

MUTING CIRCUIT PC BOARD (NAMU-1088) – PARTS LIST

CIRCUIT NO.	PARTS NO.	DESCRIPTION
Transistors		
Q701–Q706	2210747 or 2211254	2SC945A(Q1) or 2SC1815(Y)
Capacitors		
C701, C702	352753309	33 μ F, 25V, Elect.

Note:
(D): Only 120V model
(G): Only 220V model
(W): Only 120/220V model
(Q): Only 240V model

BLOCK DIAGRAM OF IC

HA-11226 BLOCK DIAGRAM

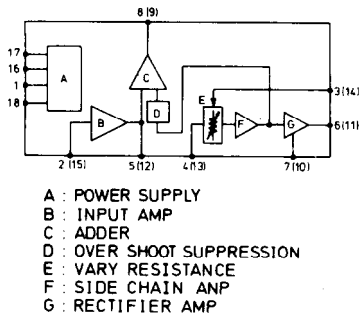

IR2E02 BLOCK DIAGRAM

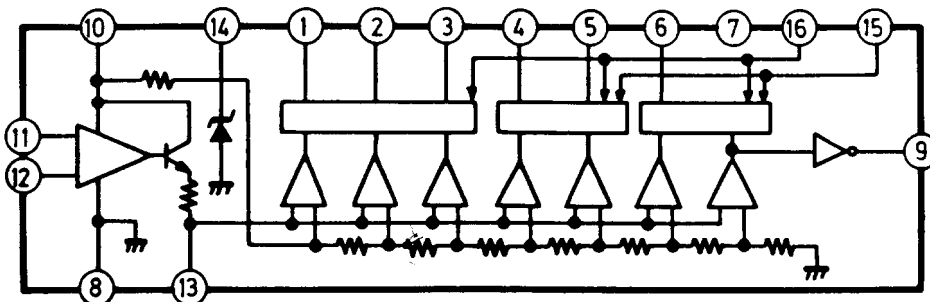

**SCHEMATIC DIAGRAM
G/W model**

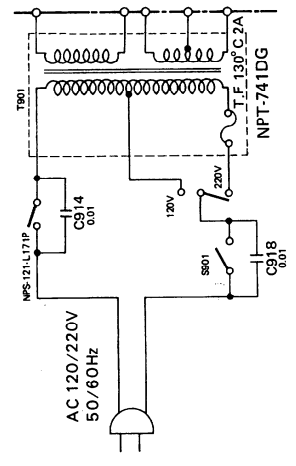
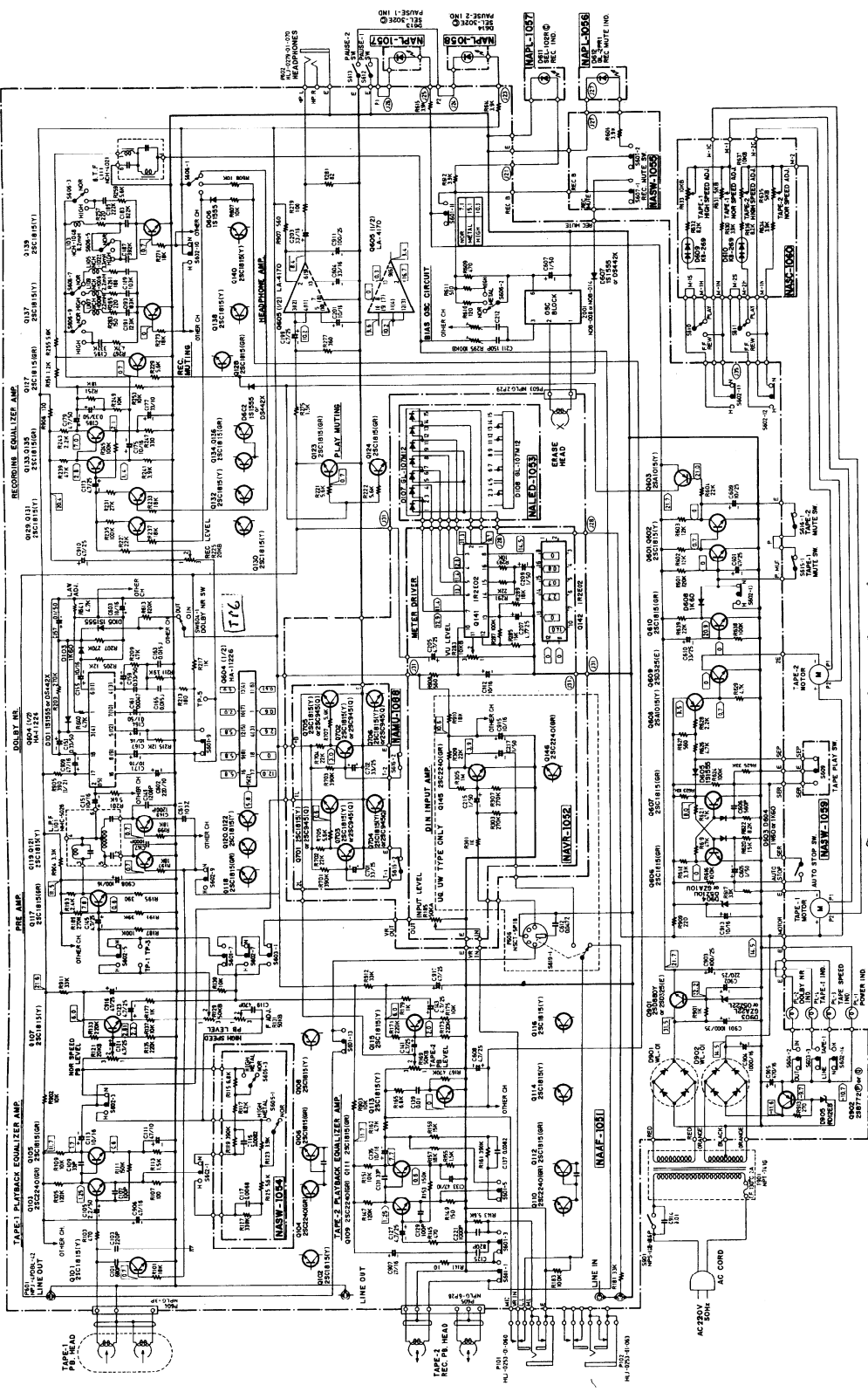

- NOTE:** RESISTORS ARE IN OHMS, μ WATT UNLESS OTHERWISE NOTED.
1. ALL CAPACITORS ARE IN μ F, 50WV UNLESS OTHERWISE NOTED.
 2. WISE NOTED.
 3. ELECTROLYTIC CAPACITORS (E) ARE IN μ F/WV.
 4. VOLTAGE IS MEASURED WITH V.T.V.M.
 5. CIRCUIT IS SUBJECT TO CHANGE FOR IMPROVEMENT.

ONKYO CORPORATION

5005	REC. SW	5005-1-1	REC. SW
5006	REC. SW	5006-1-1	REC. SW
5007	REC. SW	5007-1-1	REC. SW
5008	REC. SW	5008-1-1	REC. SW
5009	REC. SW	5009-1-1	REC. SW
5010	REC. SW	5010-1-1	REC. SW
5011	REC. SW	5011-1-1	REC. SW
5012	REC. SW	5012-1-1	REC. SW
5013	REC. SW	5013-1-1	REC. SW
5014	REC. SW	5014-1-1	REC. SW
5015	REC. SW	5015-1-1	REC. SW
5016	REC. SW	5016-1-1	REC. SW
5017	REC. SW	5017-1-1	REC. SW
5018	REC. SW	5018-1-1	REC. SW
5019	REC. SW	5019-1-1	REC. SW
5020	REC. SW	5020-1-1	REC. SW
5021	REC. SW	5021-1-1	REC. SW
5022	REC. SW	5022-1-1	REC. SW
5023	REC. SW	5023-1-1	REC. SW
5024	REC. SW	5024-1-1	REC. SW
5025	REC. SW	5025-1-1	REC. SW
5026	REC. SW	5026-1-1	REC. SW
5027	REC. SW	5027-1-1	REC. SW
5028	REC. SW	5028-1-1	REC. SW
5029	REC. SW	5029-1-1	REC. SW
5030	REC. SW	5030-1-1	REC. SW
5031	REC. SW	5031-1-1	REC. SW
5032	REC. SW	5032-1-1	REC. SW
5033	REC. SW	5033-1-1	REC. SW
5034	REC. SW	5034-1-1	REC. SW
5035	REC. SW	5035-1-1	REC. SW
5036	REC. SW	5036-1-1	REC. SW
5037	REC. SW	5037-1-1	REC. SW
5038	REC. SW	5038-1-1	REC. SW
5039	REC. SW	5039-1-1	REC. SW
5040	REC. SW	5040-1-1	REC. SW
5041	REC. SW	5041-1-1	REC. SW
5042	REC. SW	5042-1-1	REC. SW
5043	REC. SW	5043-1-1	REC. SW
5044	REC. SW	5044-1-1	REC. SW
5045	REC. SW	5045-1-1	REC. SW
5046	REC. SW	5046-1-1	REC. SW
5047	REC. SW	5047-1-1	REC. SW
5048	REC. SW	5048-1-1	REC. SW
5049	REC. SW	5049-1-1	REC. SW
5050	REC. SW	5050-1-1	REC. SW
5051	REC. SW	5051-1-1	REC. SW
5052	REC. SW	5052-1-1	REC. SW
5053	REC. SW	5053-1-1	REC. SW
5054	REC. SW	5054-1-1	REC. SW
5055	REC. SW	5055-1-1	REC. SW
5056	REC. SW	5056-1-1	REC. SW
5057	REC. SW	5057-1-1	REC. SW
5058	REC. SW	5058-1-1	REC. SW
5059	REC. SW	5059-1-1	REC. SW
5060	REC. SW	5060-1-1	REC. SW
5061	REC. SW	5061-1-1	REC. SW
5062	REC. SW	5062-1-1	REC. SW
5063	REC. SW	5063-1-1	REC. SW
5064	REC. SW	5064-1-1	REC. SW
5065	REC. SW	5065-1-1	REC. SW
5066	REC. SW	5066-1-1	REC. SW
5067	REC. SW	5067-1-1	REC. SW
5068	REC. SW	5068-1-1	REC. SW
5069	REC. SW	5069-1-1	REC. SW
5070	REC. SW	5070-1-1	REC. SW
5071	REC. SW	5071-1-1	REC. SW
5072	REC. SW	5072-1-1	REC. SW
5073	REC. SW	5073-1-1	REC. SW
5074	REC. SW	5074-1-1	REC. SW
5075	REC. SW	5075-1-1	REC. SW
5076	REC. SW	5076-1-1	REC. SW
5077	REC. SW	5077-1-1	REC. SW
5078	REC. SW	5078-1-1	REC. SW
5079	REC. SW	5079-1-1	REC. SW
5080	REC. SW	5080-1-1	REC. SW
5081	REC. SW	5081-1-1	REC. SW
5082	REC. SW	5082-1-1	REC. SW
5083	REC. SW	5083-1-1	REC. SW
5084	REC. SW	5084-1-1	REC. SW
5085	REC. SW	5085-1-1	REC. SW
5086	REC. SW	5086-1-1	REC. SW
5087	REC. SW	5087-1-1	REC. SW
5088	REC. SW	5088-1-1	REC. SW
5089	REC. SW	5089-1-1	REC. SW
5090	REC. SW	5090-1-1	REC. SW
5091	REC. SW	5091-1-1	REC. SW
5092	REC. SW	5092-1-1	REC. SW
5093	REC. SW	5093-1-1	REC. SW
5094	REC. SW	5094-1-1	REC. SW
5095	REC. SW	5095-1-1	REC. SW
5096	REC. SW	5096-1-1	REC. SW
5097	REC. SW	5097-1-1	REC. SW
5098	REC. SW	5098-1-1	REC. SW
5099	REC. SW	5099-1-1	REC. SW
5100	REC. SW	5100-1-1	REC. SW

PACKING PROCEDURES

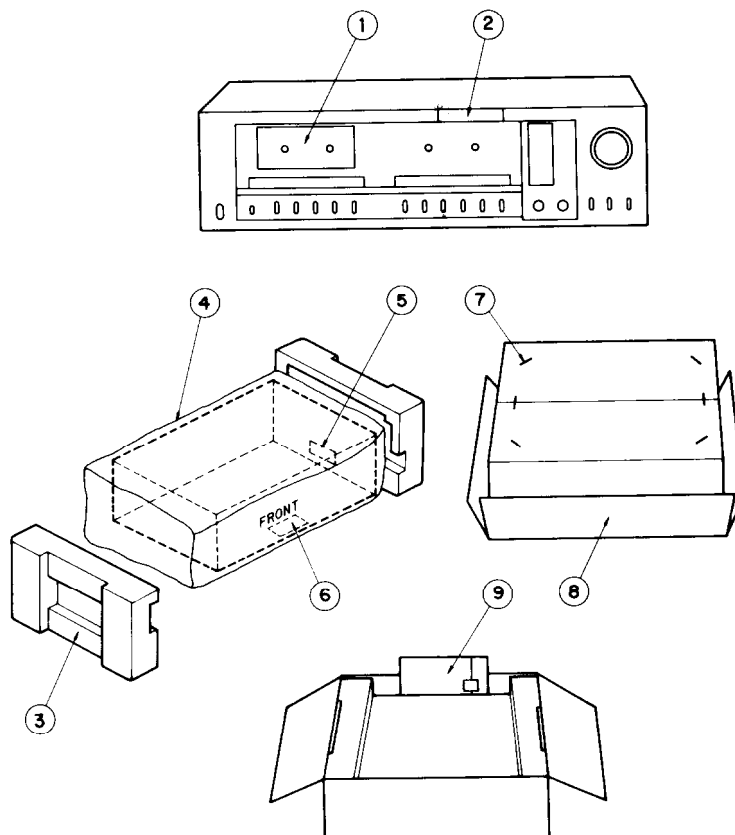

REF. NO.	PARTS NO.	DESCRIPTION
1	29380072	Instruction sheet (D)
	29380074	Instruction sheet (G/W/Q)
2	29360484	Caution label
3	29090565B	Pad
4	29100037	650x500mm, Poly bag
5	29360378	Label (DN)
6	29360363	Caution label (DN)
7	282301	Sealing hook
8	29050447	Master carton box
9		Accessory bag ass'y
	29340503	Instruction manual (D/Q)
	29340504	Instruction manual (G/W)
	253074	Connection cables
	25055018	Conversion plug (W)
	29358002	Service station list (DN)
	29365006-1	Warranty card (DN)
	29365005-3	Warranty card (GV)
	29100005	330x220mm, Poly bag

Note:

(D): Only 120V model
 (G): Only 220V model
 (W): Only 120/220V model
 (Q): Only 240V model
 (GV): Only West Germany
 (DN): Only U.S.A. model

ONKYO® SERVICE MANUAL II

STEREO CASSETTE TAPE DECK MODEL TA-W80

OPERATIONAL PROBLEMS

SYMPTON 1 : CASSETTE CAN NOT BE REMOVED.

1. When the power switch is turned off during the play or record modes, the head chassis assembly will remain up and the cassette can not be removed. If this happens, turn the power on again and remove the cassette from the cassette holder after pressing the stop button to lower the head chassis assembly.
2. If the TAPE PLAY switch is changed to the CONT. (⏮) position while TAPE-2 is in the play or record mode, the TAPE-2 head chassis assembly will stay up, power will be turned off to the motor, the TAPE-2 section will stop moving and the tape can not be removed. If this happens, return the TAPE PLAY switch to the SEP. (⏸) position and press the stop button to lower the head chassis assembly.

SYMPTON 2 : TAPE-1 TO TAPE-2 CONTINUOUS PLAYBACK NOT POSSIBLE A SECOND TIME.

To perform continuous playback immediately after the continuous playback mode has been used, return the TAPE PLAY switch to the SEP. (⏸) and then switch back to the CONT. (⏮) position. The circuit switches to the SEP. mode as soon as playback goes from TAPE-1 to TAPE-2 in the continuous playback mode.

SYMPTON 3 : WHEN THE PLAY BUTTON IS PRESSED, THE HEAD CHASSIS ASSEMBLY DOES NOT GO UP.

If you push down on the head chassis 1 (2) while the unit is in the play or record mode, the head chassis 1 (2) will lock in the down position. The cause of this problem is that the hook on the head chassis-2 (3) is caught on the head chassis 1 (2). To solve the problem, push the head chassis 1 (2) side downward with a screwdriver to let the head chassis 2 (3) hook come free and return the head chassis 1 (2) to its normal position.

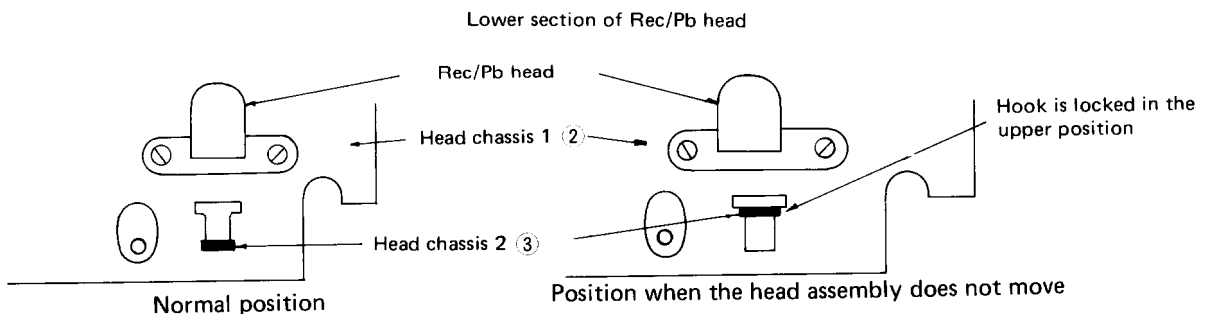

(fig. 1)

REMOVING AND REASSEMBLING THE BUTTON PANEL

1. Remove the three screws (A536) holding the top cover and back panel and the two screws (A535) holding the top cover and side brackets. Then remove the cushion (A503) on the front panel and the six screws (A502) holding the front panel and front bracket.

EXPLODED VIEW

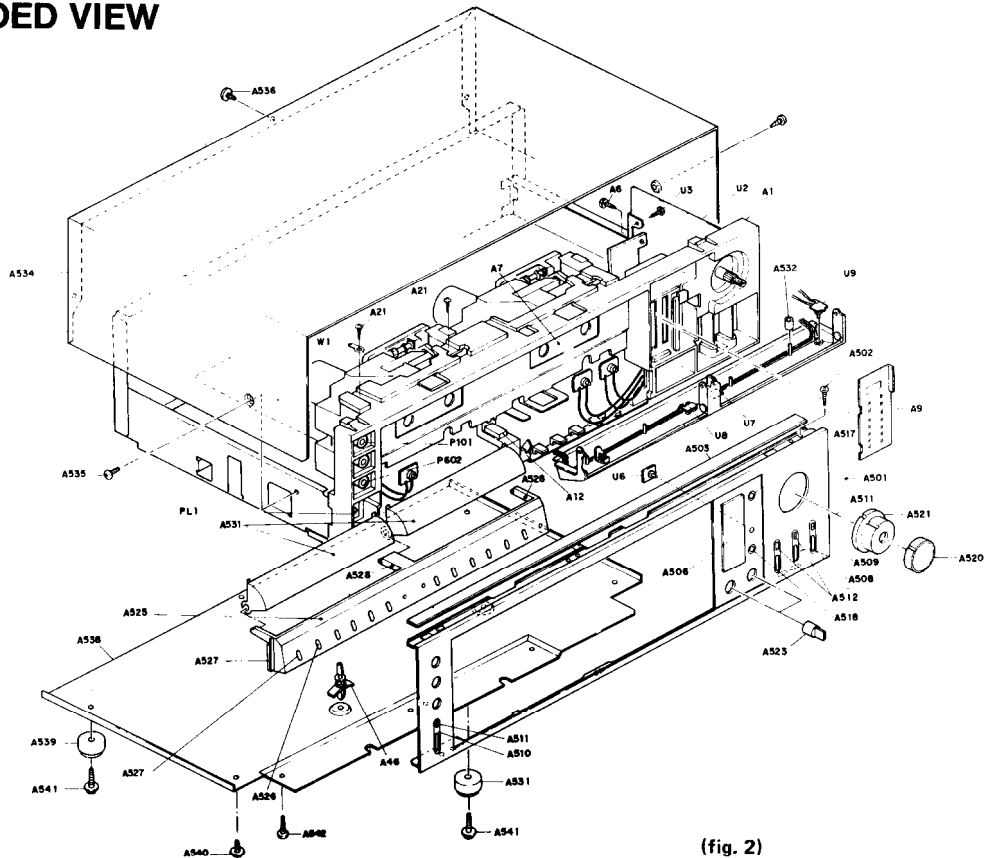

(fig. 2)

2. As shown in the figure 3, remove the felt on the left and right sides of the button panel.

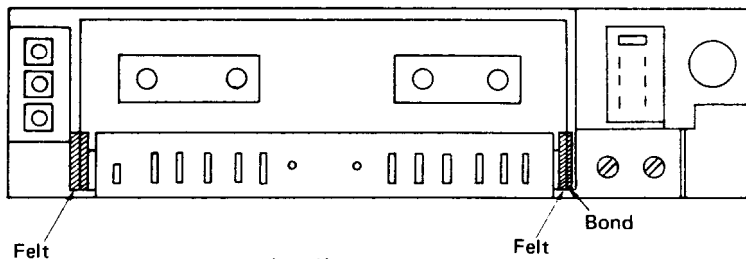

(fig. 3)

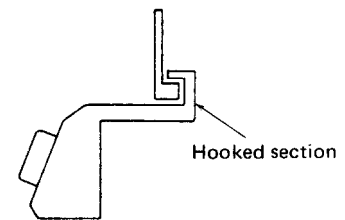

(fig. 4)

3. The front bracket and button panel are fastened together with bond and the center section is inserted from below and hooked to the front bracket as shown in the figure 4.
4. Remove the button panel by pulling the left and right ends of the lower part upward and outward. Remove the center section while pushing the hooked section toward the rear.
5. When reassembling, arrange the parts as shown in the figure 5 to be sure none of the lead wires that protrude from the left and right sides do not catch on the mechanism section.

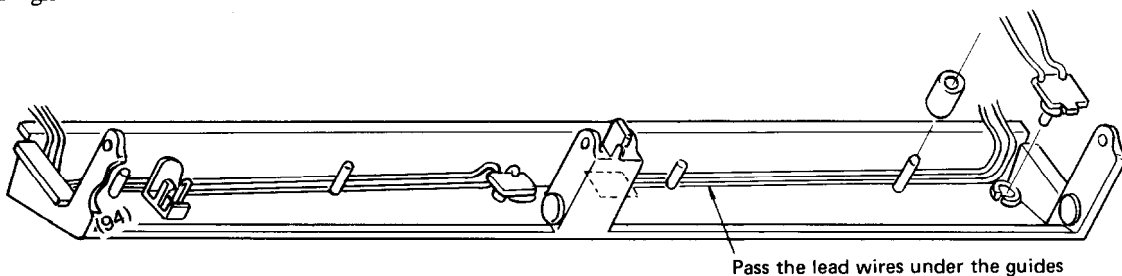

(fig. 5)

REPLACING THE CASSETTE MECHANISM (TAPE-1 AND TAPE-2)

FOR THE CASSETTE MECHANISM OF TAPE-1 (ON THE LEFT SIDE)

1. Remove the top cover.
2. Remove the front panel.
3. Remove the four screws (A540) holding the bottom board and side brackets and the two screws (A541) holding the bottom board and legs.
4. Remove the four screws (A542) holding the bottom board and front brackets and then remove the two holders from the bottom board by pressing against the holder from both sides (See figure 6).
5. Remove the two screws holding the NASC-1060 (speed control pc board assembly) and bracket from the rear of the mechanism.
6. Remove the two attachment screws on the top and the attachment screw on the bottom of the mechanism.
7. Remove the headphone jack and the two microphone jacks by pressing in from both sides (See figure 7).
8. Remove the 17 lead wires and the socket from the mechanism (See figure 8).
9. When removing the mechanism from the deck, pull the mechanism toward the rear while pressing down the NAAF-1051 pc board a little.

Caution : Make sure the heads are down

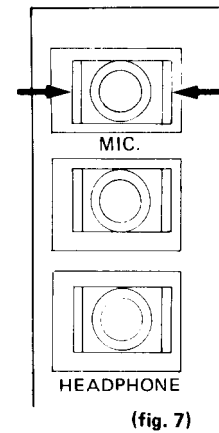
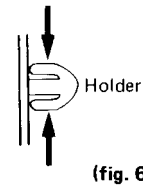

FOR THE CASSETTE MECHANISM OF TAPE-2 (ON THE RIGHT SIDE)

1. Perform steps one through three and step five above.
2. Remove the 13 lead wires from the mechanism and socket (See figure 9).
3. Remove the counter belt (133) from the counter pulley.
4. Remove the recording spring.

MECHANISM WIRING

TAPE-1

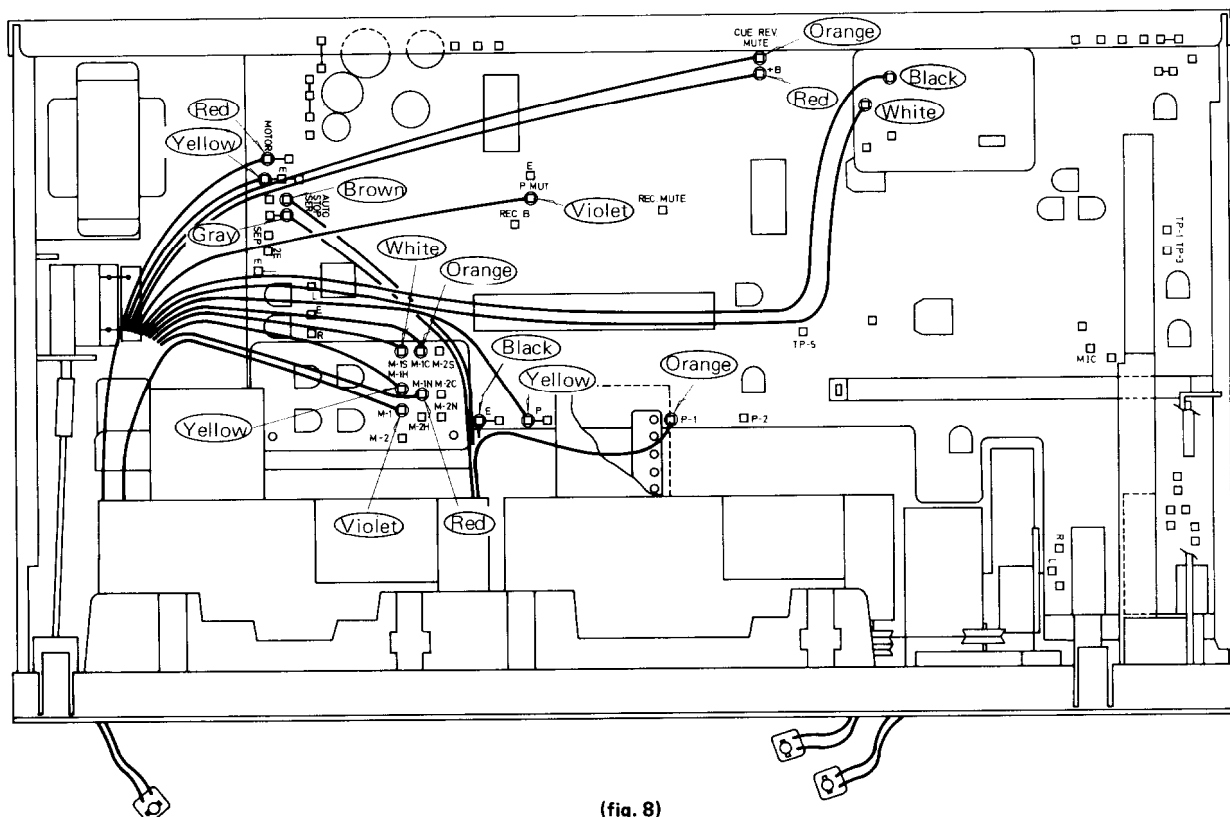

TAPE-2

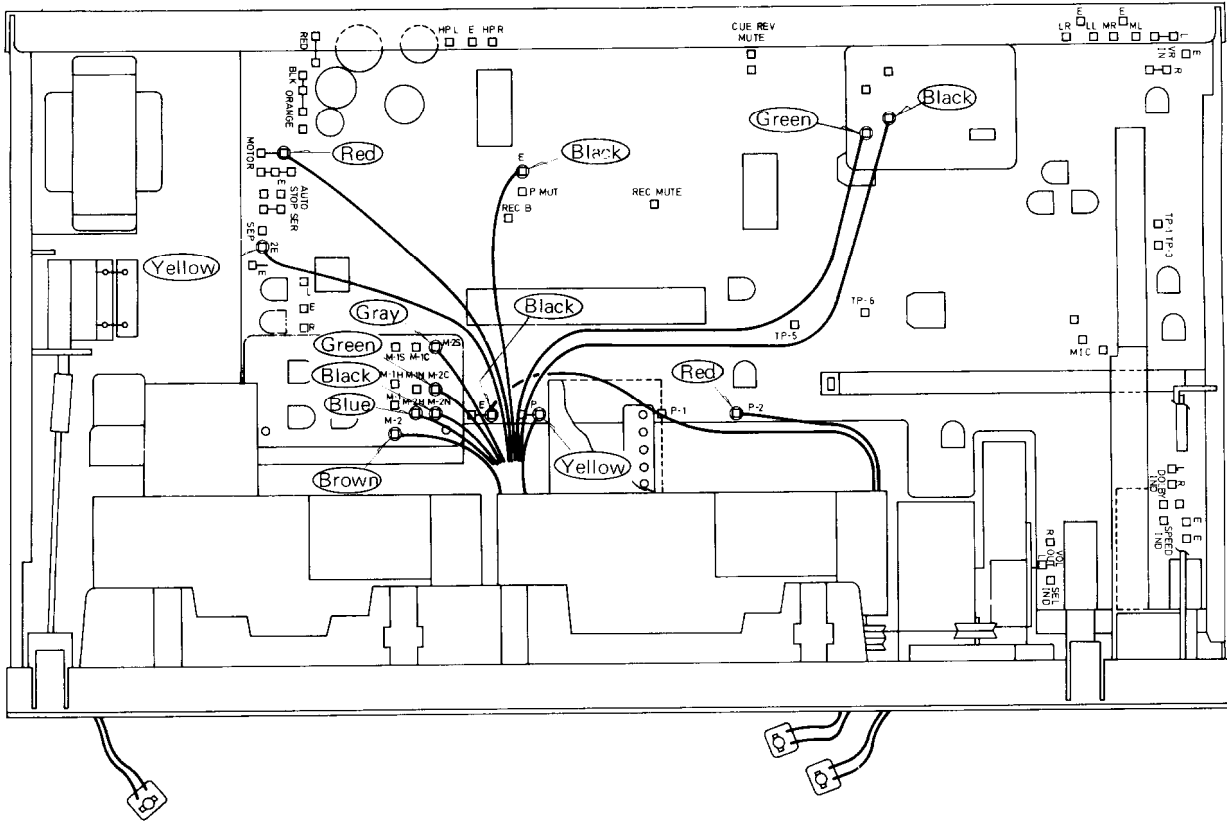

(fig. 9)

REPLACING THE MOTOR

1. Remove the cassette mechanism from the deck when replacing the motor of TAPE-2.
2. Remove the two screws on the right side of the auto-stop assembly and the two screws on the motor installation panel.
3. Remove the belt from motor pulley.
4. Remove the motor from the motor installation panel. (See figure 10)
5. When replacing the motor of TAPE-1, perform steps two through four above.

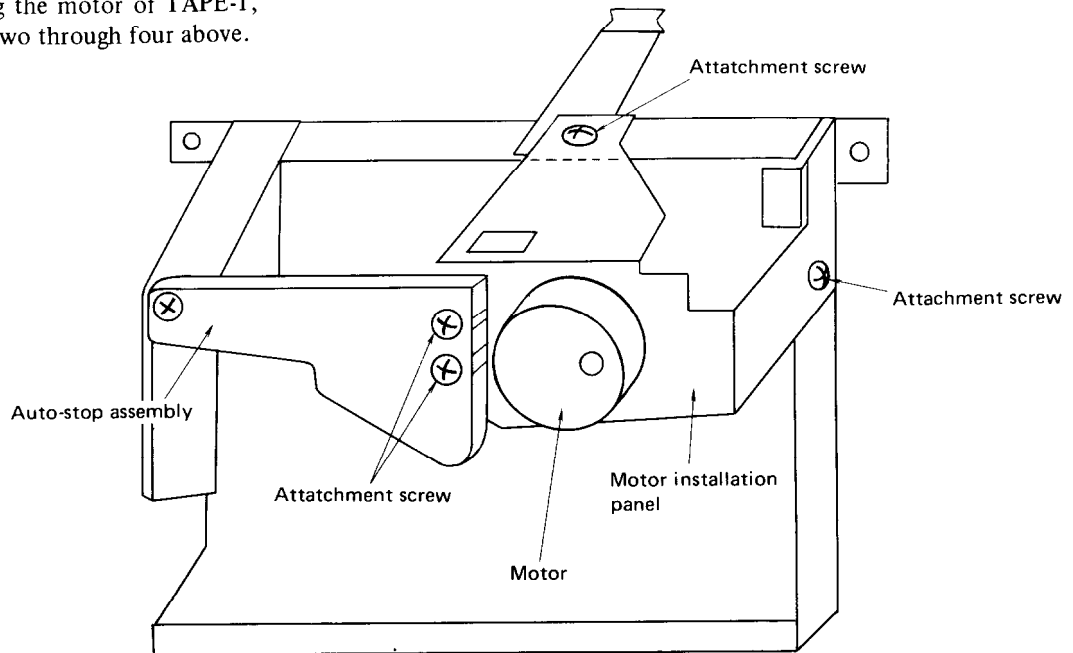

(fig. 10)

REPAIR PROCEDURES

SYMPTON 1 : ONE OR MORE BUTTONS DO NOT OPERATE (DO NOT RETURN)

CAUSE 1 : The button is caught on the edge of the button panel.

REPAIR PROCEDURE

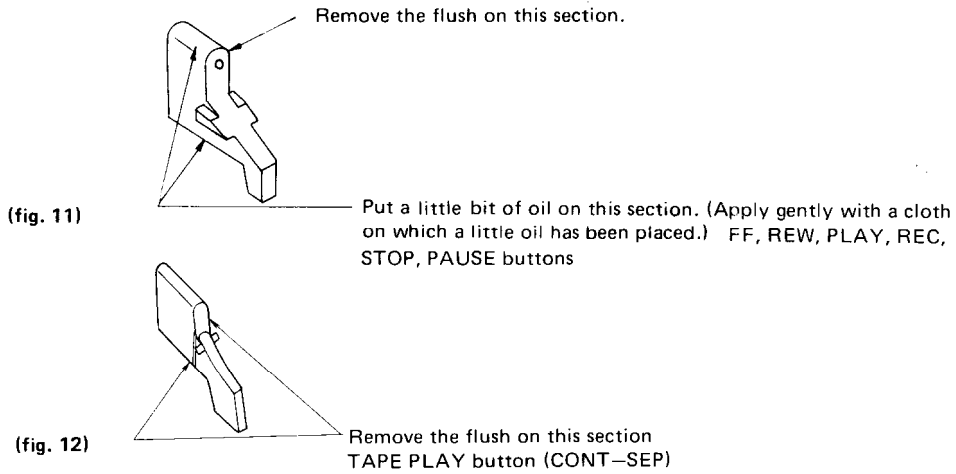

CAUSE 2 : Defect in the mechanism (stop button does not return, auto stop does not operate)

REPAIR PROCEDURE

1. The defect make the stop lever 1 ⑧4 stroke incorrect. To correct this problem, turn the adjustment screw a little bit to the clockwise direction. Be careful not to loosen the adjustment screw as this could cause the auto-stop mechanism to be off target.
2. When the spring of the stop lever 1 ⑧4 is deformed, replace the part.

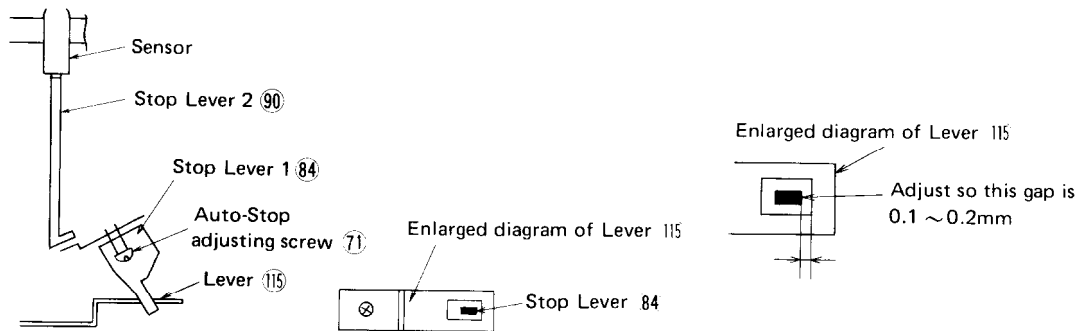

Status when defective
(fig. 13)

SYMPTON 2 : AUTO-STOP OPERATES DURING THE PLAY MODE.

CAUSE : The movement of the sensor is restricted.

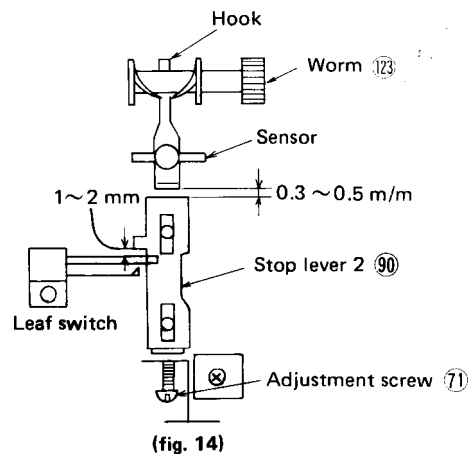

During tape transport, the sensor should move left and right and the tip of the worm and the sensor should not come in contact with each other.

REPAIR PROCEDURE

1. If the problem is caused by the sensor spring catching on something or flush on the sensor, replace the auto-stop assembly (122). (PN 24610629) (PN : Parts No.)
2. If there is not a gap of 0.3 ~ 0.5 mm between the sensor and stop lever 2 (90) and those two parts are rubbing each other :

- a : File down the top of stop lever 2 (90) that comes in contact with the lower part of the sensor.
- b : Stop lever 2 (90) is being held up by the leaf switch spring, so correct the position of the leaf switch. (only TAPE-1)

SYMPTON 3 : AUTO-STOP DOES NOT OPERATE.

CAUSE 1 : Insufficient stop lever 2 (90) stroke

REPAIR PROCEDURE

Turn the adjustment screw (71) counter-clockwise a little.

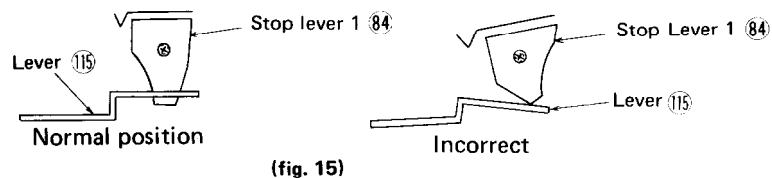

CAUSE 2 : Stop lever 1 (84) has come loose from the lever (115)

REPAIR PROCEDURE

Correct the lever (115) and adjust the adjustment screw (71)

CAUSE 3 : Defective sensor operation.

REPAIR PROCEDURE

Check if the sensor is hitting lever 2 (128) or not and repair if necessary.

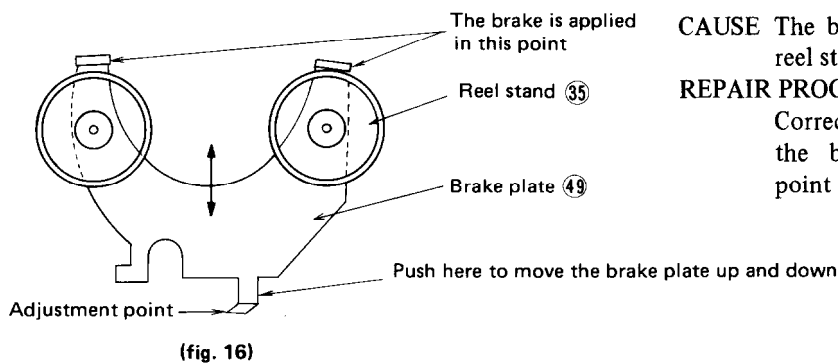
SYMPTON 4 : IMPROPER TAPE TRANSPORT; HIGH WOW AND FLUTTER.

CAUSE The brack plate (49) is rubbing against the reel stand (35)

REPAIR PROCEDURE

Correct the angle of the lower section of the brake plate (49) marked adjustment point figure 16.

SYMPTON 5 : SQUEAKS OR RATTLES DURING OPERATION

- CAUSE :
- (1) Defective slip pulley — Replace
 - (2) Defective tention pulley bracket ⑬⑩ — Replace
 - (3) Loose gear ⑳④ shaft — Replace mechanism assembly
 - (4) Worm ⑫③ thrust too big — Replace auto-stop assembly

REPAIR PROCEDURE

Removing the slip pulley ③⑥ (performed after removing the cassette mechanism from the deck.)

- (1) Remove the auto-stop assembly ⑫②
- (2) Remove the switch bracket 1 ⑰⑧
- (3) Pull out the slip pulley ③⑥ attachment shaft as shown in figure 17.
- (4) Remove the spring from the slip pulley.

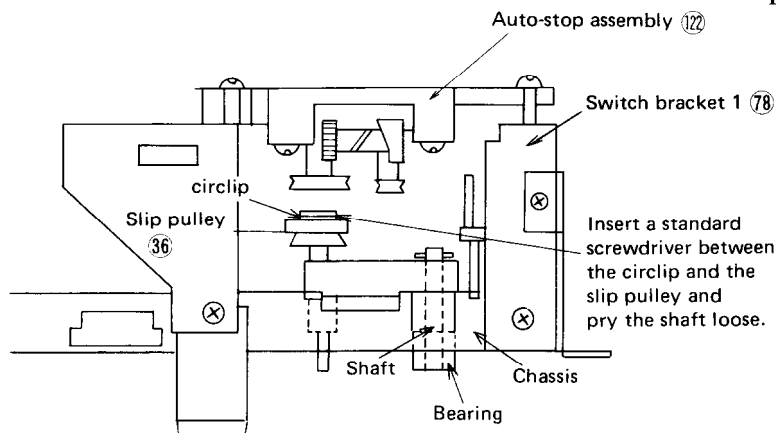

(fig. 17)

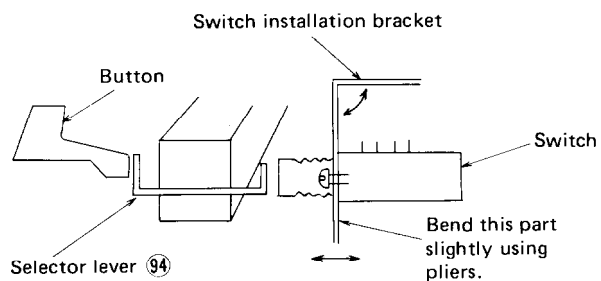
SYMPTON 6 : DEFECTIVE PLAY SWITCH (CONT-SEP)

(fig. 18)

CAUSE : Incorrect stroke

REPAIR PROCEDURE

Correct this problem by bending the bracket that holds the switch in place.

SYMPTON 7 : RECORDING CAN NOT BE PERFORMED (REC/PB SWITCH DOES NOT OPERATE)

CAUSE : Loose screw where the recording arm ⑳⑦ and recording lever 1 ⑰⑦ are connected.

REPAIR PROCEDURE

Bending the motor bracket section shown in the figure 19 makes it easier to insert the pliers. Grasp the top of the screw with the pliers and tighten it. Finally, lock the screw with the locking paint.

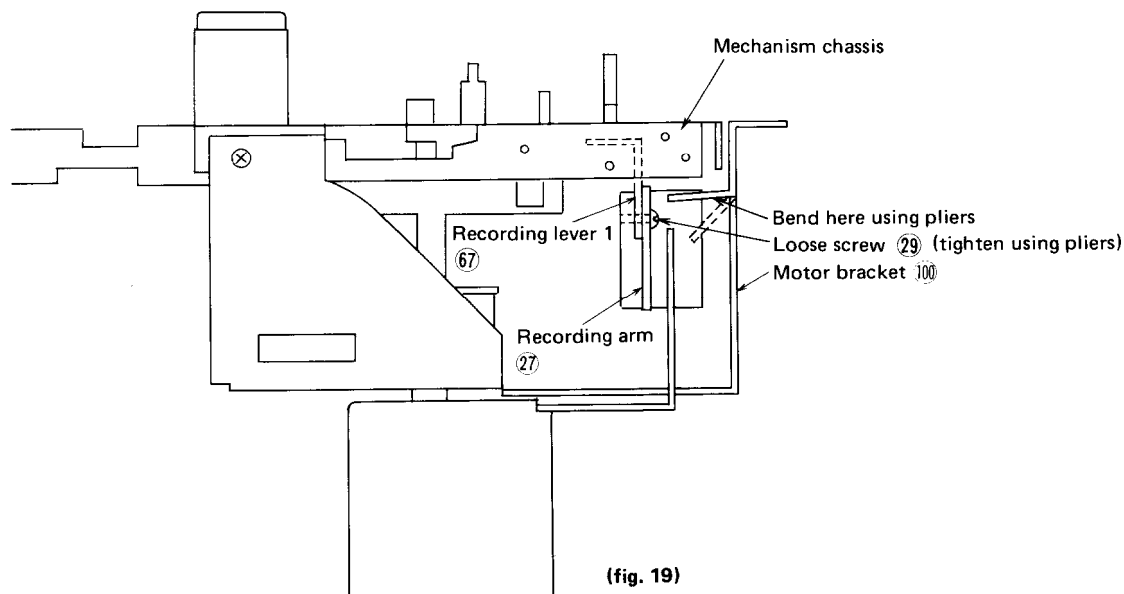

(fig. 19)

SYMPTON 8 : SPEED OF TAPE-1 AND TAPE-2 TOO FAST (OR SLOW)

In order to prevent the cassette in TAPE-2 from ending before the one in TAPE-1 when two identical tapes are used for dubbing (and started at exactly the same moment), the speed of TAPE-2 is set slightly slower than TAPE-1.

ADJUSTMENT PROCEDURE (Age the unit for 10 minutes first)

- NORMAL SPEED** Connect a frequency counter to the LINE OUT terminals and adjust the semi-fixed resistor R631 so the output frequency becomes 3,030 ~ 3,040 Hz when an MTT-111 test tape is played back in TAPE-1. Next, adjust the semi-fixed resistor R635 so the output frequency becomes 3,020 ~ 3,030 Hz when an MTT-111 test tape is played back in TAPE-2.
- HIGH SPEED** Connect a frequency counter to the LINE OUT terminals, set the tape speed switch to HIGH position and adjust the semi-fixed resistor R633 so the output frequency becomes 6,010 ~ 6,020 Hz when an MTT-111 test tape is played back in TAPE-1. Next, Short circuit TP-1 and TP-3 using a short cup and, playing back an MTT-111 test tape in TAPE-2, adjust the semi-fixed resistor R637 so the output frequency becomes 6,000 ~ 6,010 Hz.

EXPLODED VIEW

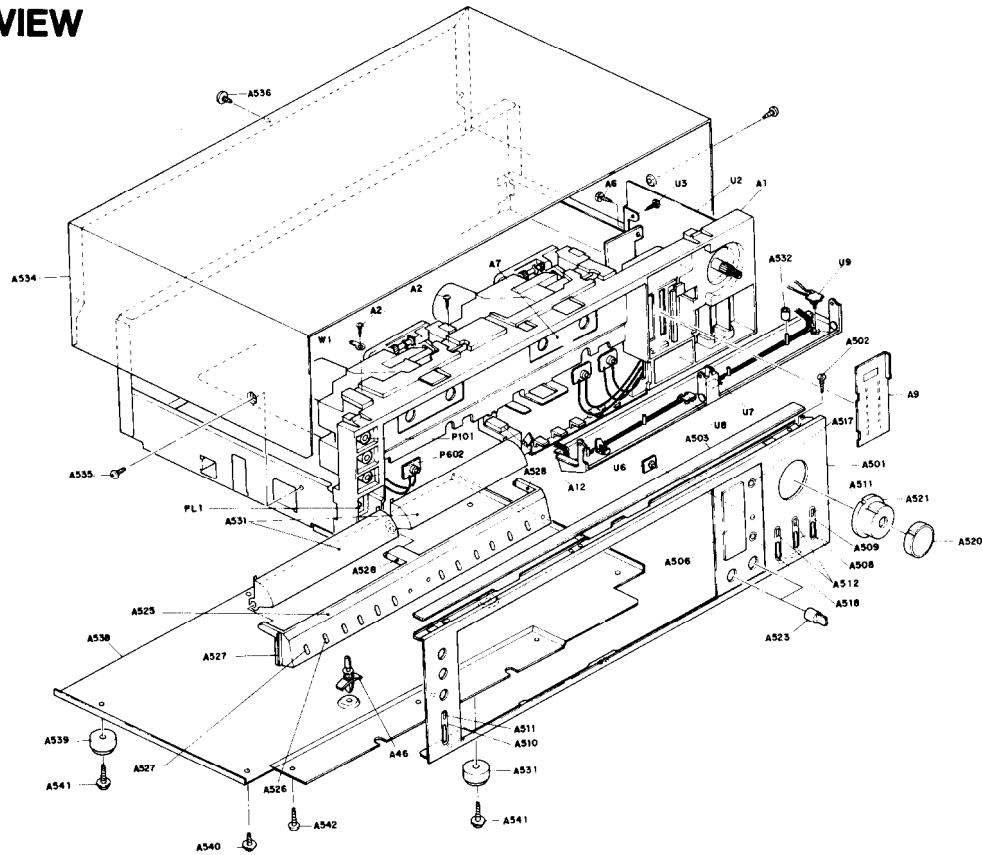

PARTS LIST

SYMBOL NO.	PARTS NO.	DESCRIPTION	SYMBOL NO.	PARTS NO.	DESCRIPTION
A1	27110130	Bracket, front	A506	28191077	Plate, clear
A2	834130102	3STS+10BQ, Tapping screw	A508	28320485	Knob, eject
A6	833130087	3TTP+8S, Tap screw	A509	27267086	Guide, push
A7	27262079	Plate		27300354	Filter
A9	28130108	Plate, dial	A510	27267087	Guide, power
A12	28140342	Cushion		27300354	Filter
A14	24601082	Counter, tape	A511	28198541A	Facet
A17	27115079A	Bracket, side	A512	28198541-1	Facet
A20	834130062	3STS+6BQ, Tapping screw	A517	27267099	Guide, meter
A22	27140479	Bracket, pc board	A518	28320519	Knob, reset/rec mute
A26	27120297A	Back panel (D)	A520	28320520-1	Knob, input level, right
	27120298A	Back panel (G)	A521	28320521-1	Knob, input level, left
	27120302A	Back panel (W)	A523	28320516	Knob, selector
	27120319A	Back panel (Q)	A525	28400027A	Frame, button
A29	831120082	3STW+8BQ, Tapping screw	A526	28320483-3	Button
A31	27130245	Bracket, pc board	A527	28320522-1	Button, tape play
A33	270025	SR-3P4, Strainrelief (D)	A528	27270056	Spacer
	270280	SR-4K-4, Strainrelief (G/W/Q)	A530	28140344	Cushion
A35	27180104	Spring	A531	27300351	Cover, head
A36	27180105	Spring	A532	27265046	Ring, rubber
A39	27130247A	Bracket, power transformer	A534	28184091-1	Top cover
A41	833140087	4TTP+8S, Tap screw	A535	834430062	3STS+6BQ(BC), Tapping screw
A43	27260059	Shaft, switch	A536	834130082	3STS+8BQ, Tapping screw
A44	28320135	Connector	A538	27170101	Bottom board
A46	27190009	Holder	A539	27175003A	Leg
A48	831130082	3STW+8BQ, Tapping screw	A540	831130062	3STW+6BQ, Tapping screw
A50	82113006	3P+6FN, Pan head screw	A541	831130082	3STW+8BQ, Tapping screw
A51	834130062	3STS+6BQ, Tapping screw	A542	834130122	3STS+12BQ, Tapping screw
A52	27130279	Bracket	C914	3500057	0.01μF, 125V, Capacitor, CS (D)
A501	16279121	Front panel ass'y	C914	3500058	PME265M510, Capacitor, IS (G)
A502	833130100	3TTP+10P, Tapping screw	C914, C918	3500058	PME265M510, Capacitor, IS (W/Q)
A503	28140252	Cushion			
A32	27130281	Bracket, pc board			
A54	27130280	Bracket, pc board			
A55	834130042	3STS+4BQ, Tapping screw			

COMPONENT LOCATION

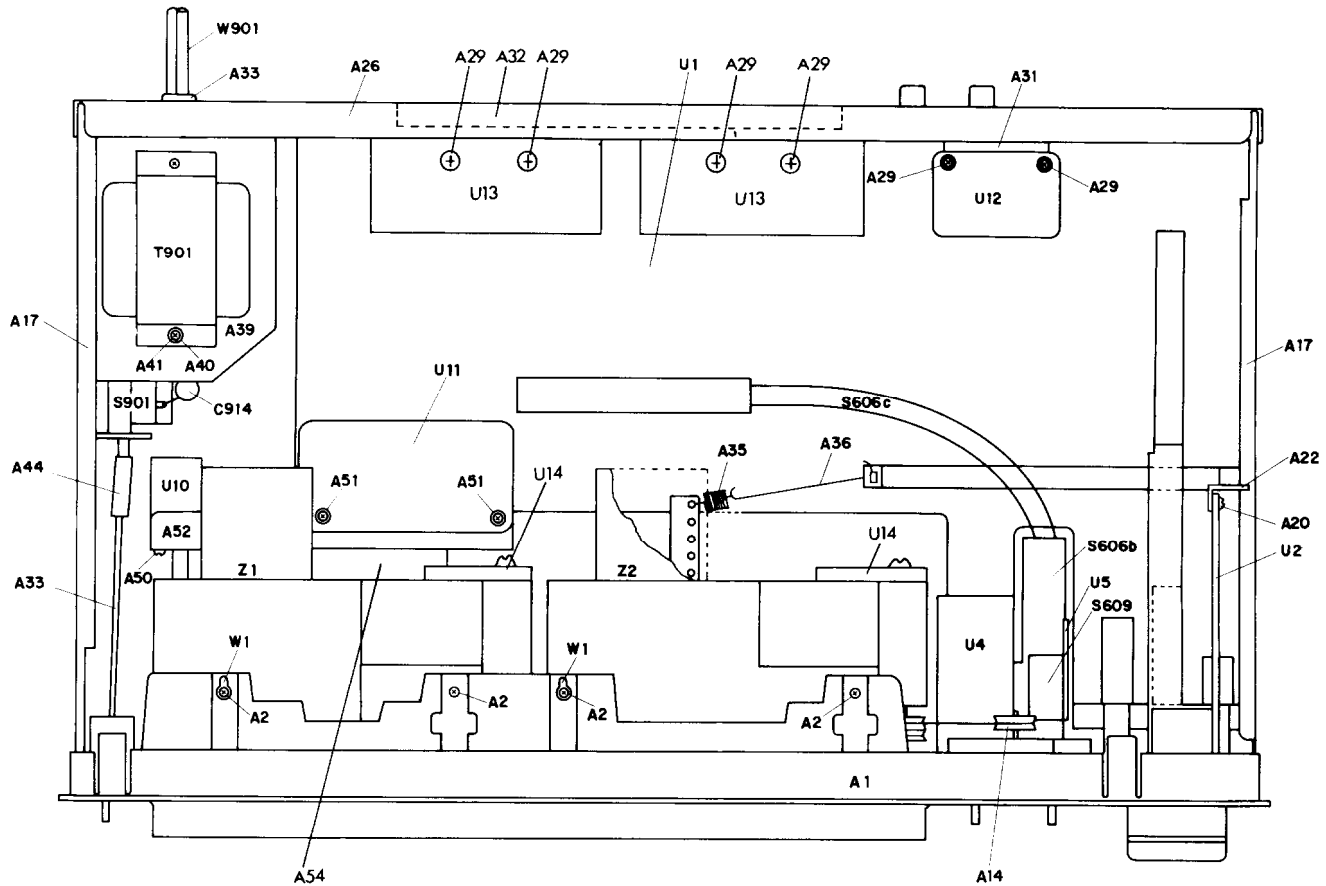

SYMBOL NO.	PARTS NO.	DESCRIPTION	SYMBOL NO.	PARTS NO.	DESCRIPTION
PL1	210083	PL14V0.06AW-3, Lamp, power	U2	16282552A	NAVR-1052a, Volume, meter and DIN amplifier pc board ass'y (G/W)
P101, P102	25045068	HLJ-0253-01-060, Microphone jack	U3	16394553	NALED-1053, VU indicator L.E.D. pc board ass'y
P602	25045067	HLJ-0279-01-070, Stereo headphone jack	U4	16394554	NASW-1054, TAPE 1 selector switch pc board ass'y
S606b	25030184-1	NRS-103-20ZV, TAPE 2 selector switch	U5	16394555	NASW-1055, Switch pc board ass'y
S606c	25065148	Wire, switch	U6	16394556	NAPL-1056, Rec. mute. indicator pc board
S901	25035224	NPS-121-L188P, Power switch (D)	U7	16394557	NAPL-1057, Rec. indicator pc board ass'y
	25035192	NPS-122-L156P, Power switch (G/Q)	U8, U9	16394558	NAPL-1058, Pause indicator pc board ass'y
	25035207	NPS-121-L171P, Power switch (W)	U10	16394559	NASW-1059, Tape play switch pc board ass'y
S902	25065123	NSS-1258P, Voltage selector switch (W)	U11	16394560	NASC-1060, Speed control pc board ass'y
T901	230496	NPT-741D, Power transformer (D)	U12	16394588	NAMU-1088, Muting circuit pc board ass'y
	230497	NPT-741G, Power transformer (G)	W1	223004	Terminal
	230498	NPT-741DG, Power transformer (W)	W901	253099A	AS-UC-3, Power supply cable (D)
	230513	NPT-741Q, Power transformer (Q)		253083	AS-CEE, Power supply cable (G/W)
U1	16279551B	NAAF-1051b, Recording and playback amplifier pc board ass'y (D/Q)		244029	NDM-24, Tape 1 ass'y
	16282551A	NAAF-1051a, Recording and playback amplifier pc board ass'y (G/W)		244030	NDM-25, Tape 2 ass'y
U2	16394552	NAVR-1052, Volume and meter circuit pc board ass'y (D/Q)	Note:		
U13	16279526	NATD-1226, Auto-stop pc board ass'y	(D): Only 120V model		
U14	16279527	NATD-1227, Auto-stop pc board ass'y	(G): Only 220V model		
			(W): Only 120/220V model		
			(Q): Only 240V model		

SCHEMATIC DIAGRAM

AUTO STOP CIRCUIT

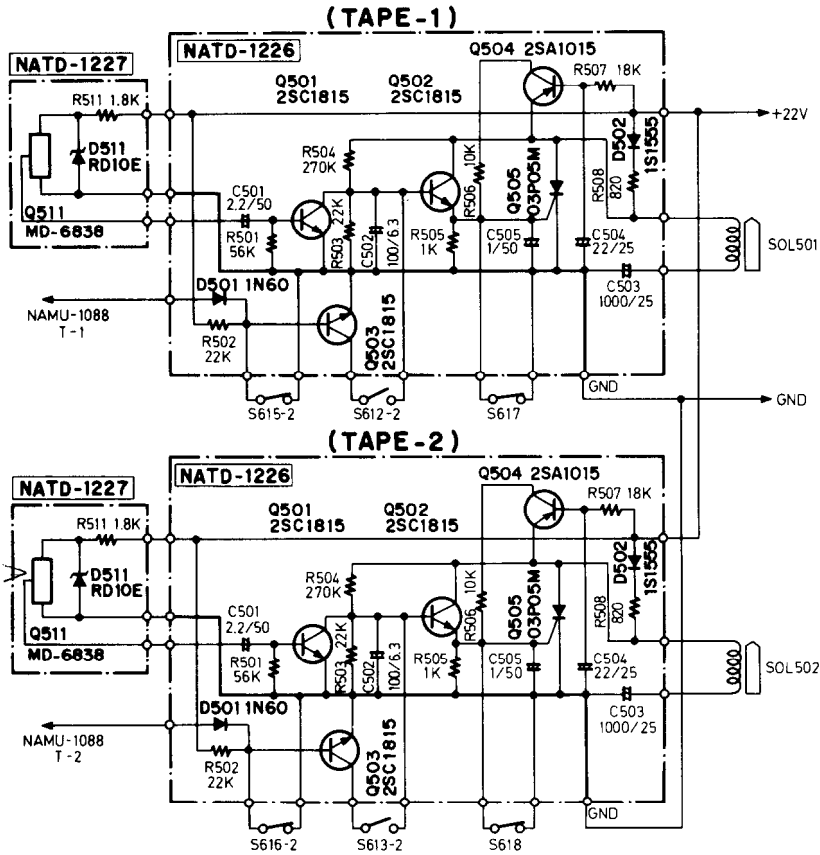

Q501	2SC1815 or 2SC945, 2SC2308
Q502	2SC1815 or 2SC945, 2SC2308
Q503	2SC1815 or 2SC945, 2SC2308
Q504	2SA1015 or 2SA733A
Q505	03P05M
Q511	MD-6838
D501	1N60
D502	1S1555 or DS442X
D511	RD10E or GZA-10

PARTS LIST

AUTO STOP CONTROL CIRCUIT (NATD-1226)

CIRCUIT NO.	PARTS NO.	DESCRIPTION
Q501-Q503	Transistors	
	2210353,	2SC945(P)
	2211673 or	2SC2308(C) or
	2211255	2SC1815(GR)
Q504	2211454 or	2SA1015(Y) or
	2210804	2SA733A(Q1)
Q505	SCR	
	225015	03P05M
D501	Diodes	
	2231031	1N60(ONK)
	223105 or	1S1555 or
D502	223133	DS-442X
C501	Capacitors, elect.	
	352780229	2.2μF, 50V
	352711019	100μF, 6.3V
	352751029	1,000μF, 2.5V
	352752209	22μF, 25V
	352780109	1μF, 50V

AUTO-STOP DETECTOR CIRCUIT (NATD-1227)

CIRCUIT NO.	PARTS NO.	DESCRIPTION
Q511	222558	DN6838, IC
D511	223959 or	RD10E-B or
	224107	GZA-10L, Diode

TAPE 1 MECHANISM — EXPLODED VIEW

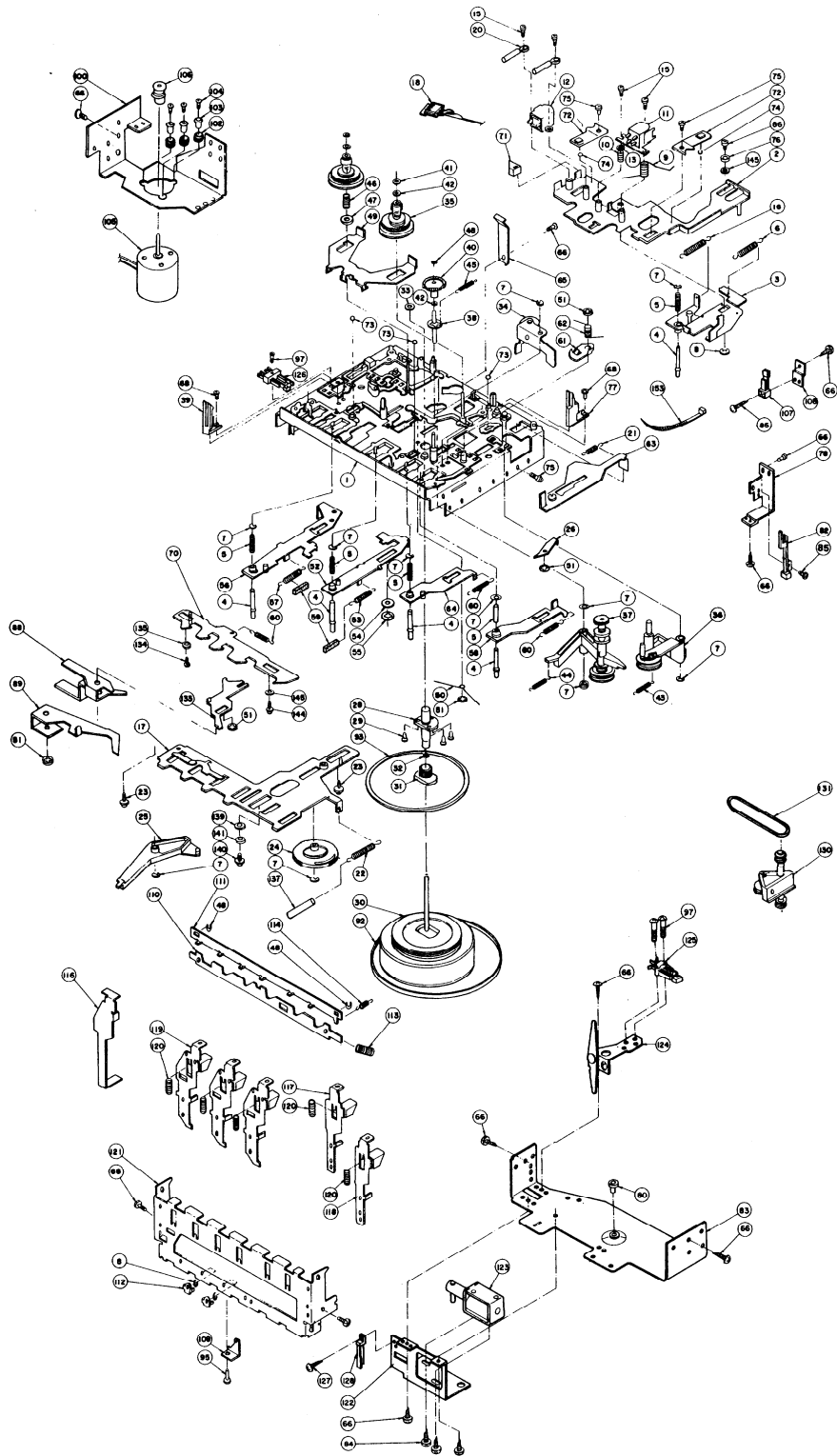

REF. NO.	PARTS NO.	DESCRIPTION
84	24610617	Pinch roller
35	24602105-1	Reel stand
36	24602126	Slip pulley
37	24610533	FF/REW arm
38	24610534	Slider
39	24610535-1	Holder (L)
40	24602112	Gear
41	24610565	PSW1.6x3.2x0.25, Washer
42	24610566	PSW2x4x0.25, Washer
43	24605254	Spring for 36
44	24605255	Spring for 37
46	24605257	Spring for back tension
47	24610569	NW4x10x0.5, Washer
48	893015	E-1.5, Circlip
49	24610618	Brake plate
50	24605271	Spring for brake
51	891030	CS3, CS ring
52	24603165	FF lever ass'y
53	24605282	Spring for 52
54	8761401005	FW4x10x0.5, Washer
55	891040	CS4, CS ring
56	24603195	Rewind lever
57	24605306	Spring for 56
58	24603167	Pause lever
59	24610580	Cushion
60	24605261	Spring
61	24610619	Pause cam
62	24605262	Spring for 61
63	24603168	Pause lever 2
64	24603169	Stop lever
65	24605263	Cassette holding spring
66	833130059	CT3x5, Screw
68	82112604	FM2.6x4, Screw
70	24610676	Locking plate
71	24610625	Switch chip
72	24605265	Spring for head chassis holding
73	24610542	3ø, Steelball
74	24610543	2ø, Steelball
75	831126042	TPT+2.6x4, Screw
76	8761420704	FW4.2x7x0.4, Washer
77	24610536-1	Holder (R)
78	24610677	Switch bracket
79	833126069	CT2.6x6, Screw
80	24610571	Thrust adjusting screw
82	24606121	Leafswitch
83	24610678	Flywheel bracket
84	82113004	FM3x4, Screw
85	833126069	CT2.6x6, Screw
86	833126080	2.6x8, Screw
88	24603207	Selector lever 1
89	24603181	Selector lever 2
91	24610588	NW3.2x8x0.3, Washer
92	24602106	Belt
93	24602107	Belt
95	833130089	CT3x8, Screw
96	24603179	Leafswitch
97	82112010	FMT2x10, Screw
100	24610679	Motor bracket
102	24610550	Motor cushion
103	24604040	Pipe
104	801178	2.6x8, Sems screw
105	24601089-1	Motor ass'y
106	24601097	Motor pulley
	801183	2x4, Screw for pulley
107	24606122	Leafswitch
108	24610680	Switch bracket
109	24610551	Bracket for spring
110	24610552	Trigger cam
111	24610553	Locking plate
112	24610554	Seesaw cam
113	24695291	Spring
114	24605281	Spring for 111
116	24610587	Operation lever 4
117	24610555	Operation lever 3
118	24610556	Operation lever 2
119	24610557	Operation lever 1
120	24605269	Spring
121	24610558	Operation lever bracket
122	24610681	Bracket
123	24606123	Solenoid
124	24610682	Bracket
125	24603184	Skeleton switch
126	24603196	Leafswitch
127	833120062	FMT2x6, Screw
128	24606124	Leafswitch
130	24610683	Tension pulley
131	24602121	Belt
132	24610684	Bracket
133	24603208	Switch lever
134	82112608	FM+2.6x8, Screw
135	24610583	Spacer
137		Tube
139	24610577	Felt
140	831130082	TPT3x8, Screw
141	8761321205	FW3.2x12x0.5, Washer
143	831126062	TPT2.6x6, Screw
144	833126052	TP2.6x5, Screw
145	8761260805	FW2.6x7.5x0.5, Washer
150	876130803	FW3x8x0.3, Washer
151	24605273	Spring
153	260208	Binder

REF. NO.	PARTS NO.	DESCRIPTION
1	24610522	Chassis
2	24610615-1	Head chassis 1
3	24610616	Head chassis 2
4	24604042	Shaft
5	24605248	Spring for 4
6	24605305	Spring for 3
7	893020	E-2, Circlip
8	893030	E-3, Circlip
9	24605250	Spring
10	24605284	Head azimuth adjusting spring
11	24600028	Rec/pb head
12	24600029	Dummy head
13	8761267505	FW2.6x7.5x0.5, Washer
15	801237	2x6mm, Screw
16	24605286	Spring for 3

REF. NO.	PARTS NO.	DESCRIPTION
17	24610675	Actuating plate
18	25050088	Rec/pb connector
20	24610623	Terminal
21	24605295	Spring
22	24605277	Spring for 17
23	831130062	TPT+3x6mm, Screw
24	24602111	Gear
25	24610528	Trigger arm
26	24610529	Canceller arm
28	24610531	Flywheel holder
29	833126059	CT2.6x5, Screw
30	24602103	Flywheel
31	24602104	Flywheel gear
32	24610564	PSW2.5x4.7x0.25, Washer
33	24610567	2.4x8x0.3, Washer, Nylon

TAPE 2 MECHANISM — EXPLODED VIEW

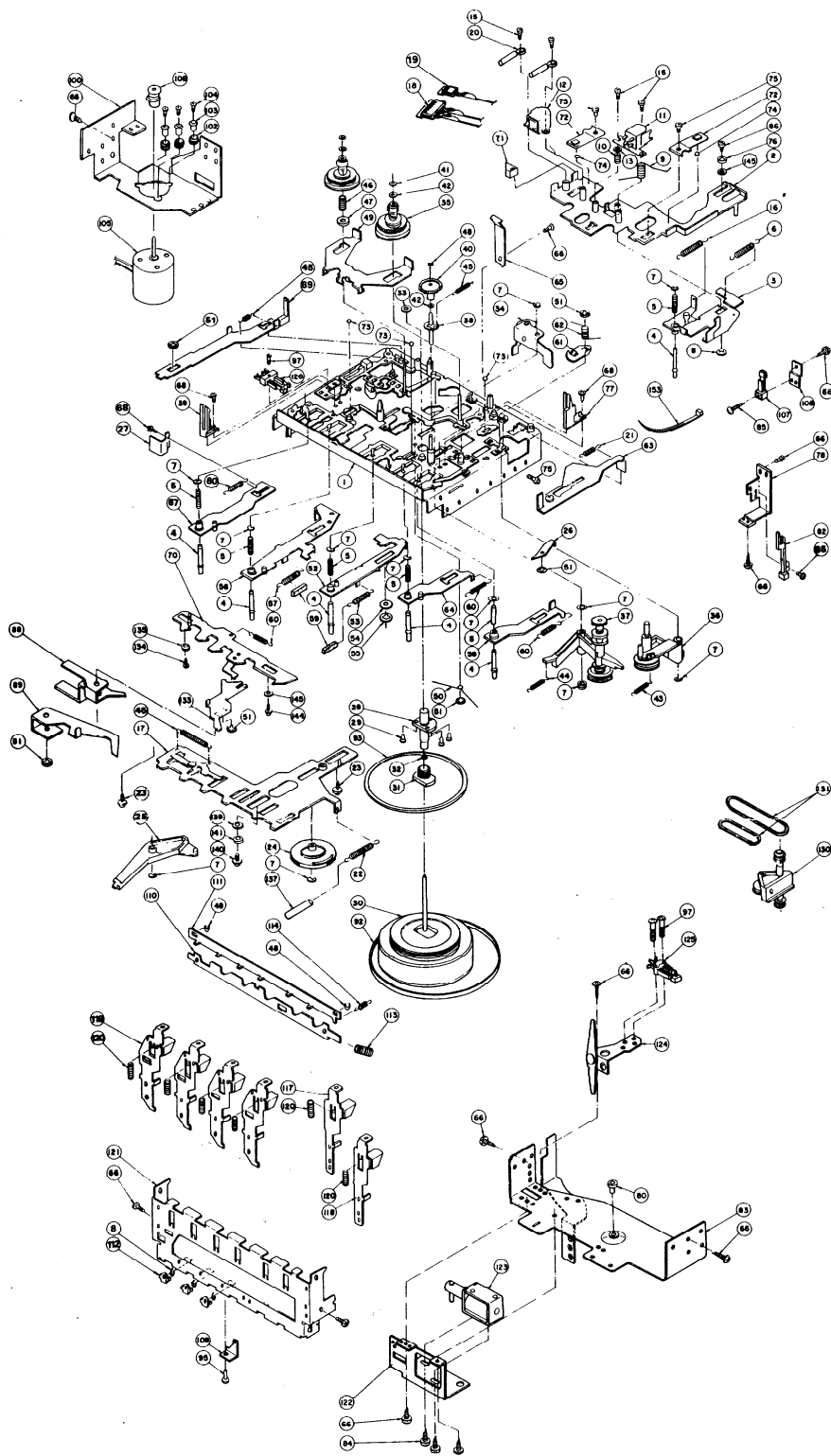

REF. NO.	PARTS NO.	DESCRIPTION
36	24602126	Slip pulley
37	24610533	FF/REW arm
38	24610534	Slider
39	24610535-1	Holder (L)
40	24602112	Gear
41	24610565	PSW1.6x3.2x0.25, Washer
42	24610566	PSW2.4x0.25, Washer
43	24605254	Spring for 36
44	24605255	Spring for 37
45	24695256	Spring
46	24605257	Spring for back tension
47	24610569	NW4x10x0.5, Washer
48	893015	E-1.5, Circlip
49	24610618	Brake plate
50	24605271	Spring for brake
51	891030	CS3, CS ring
52	24603165	FF lever ass'y
53	24605282	Spring for 52
54	8761401005	FW4x10x0.5, Washer
55	891040	CS4, CS ring
56	24603166	Rewind lever
57	24605306	Spring for 56
58	24603167	Pause lever
59	24610580	Cushion
60	24605261	Spring
61	24610593	Pause cam
62	24605262	Spring for 61
63	24603168	Pause lever 2
64	24603169	Stop lever
65	24605263	Cassette holding spring
66	833130059	CT3x5, Screw
67	24603170	Recording lever 1
68	82112604	FM2.6x4, Screw
69	24610540	Lever
70	24610686	Locking plate
71	24610625	Switch chip
72	24605265	Spring
73	24610542	3ø, Steelball
74	24610543	2ø, Steelball
75	831126042	TPT+2.6x4, Screw
76	8761420704	FW4.2x7x0.4, Washer
77	24610536-1	Holder (R)
78	24610677	Switch bracket
79	833126069	CT2.6x6, Screw
80	24610571	Thrust adjusting screw
82	24606121	Leafswitch
83	24610678	Flywheel bracket
84	82113004	FM+3x4, Screw
85	833126069	CT2.6x6, Screw
86	833126080	ø8, Screw
88	24603207	Selector lever 1
89	24603181	Selector lever 2
91	24610588	NW3.2x8x0.3, Washer
92	24602106	Belt
93	24602107	Belt
95	833130089	CT3x8, Screw
96	24603179	Leafswitch
97	833120102	FMT2x10, Screw
100	24610679	Motor bracket
102	24610550	Motor cushion
103	24604040	Pipe
104	801178	2.6x8, Sems screw
105	24601087-1	Motor ass'y
106	24601097	Motor pulley
801183		2x4, Screw for pulley
107	24606122	Leafswitch
108	24610680	Switch bracket
109	24610551	Bracket for spring
110	24610552	Trigger cam
111	24610553	Locking plate
112	24610554	Secesaw cam
113	24605291	Spring
114	24605281	Spring
117	24610555	Operation lever 3
118	24610556	Operation lever 2
119	24610557	Operation lever 1
120	24605269	Spring
121	24610558	Operation lever bracket
122	24610681	Bracket
123	24606123	Solenoid
124	24610682	Bracket
125	24603184	Skeleton switch
126	24603196	Leafswitch
130	24610683	Tension pulley bracket
131	24602121	Belt
132	24610684	Bracket
133	24603208	Switch lever
134	82112608	FM+2.6x8, Screw
135	24610583	Spacer
137		Tube
139	24610577	Felt
140	831130082	TPT3x8, Screw
141	8761321205	FW3.2x12x0.5, Washer
140	831126082	TPT2.6x6, Screw
144	833126052	TP2.6x5, Screw
145	8761260805	FW2.6x7.5x0.5, Washer
150	8761300803	FW3x8x0.3, Washer
151	24605273	Spring
152		Tube
153	260208	Binder
	24601089-1	Motor

REF. NO.	PARTS NO.	DESCRIPTION
1	24610522	Chassis
2	24610615-1	Head chassis 1
3	24610616	Head chassis 2
4	24604042	Shaft
5	24605248	Spring for 4
6	24605289	Spring
7	893020	E-2, Circlip
8	893030	E-3, Circlip
9	24605250	Spring
10	24605284	Head azimuth adjusting spring
11	24600028	Rec/pb head
12	24600015	Erase head
15	801237	2x6mm, Screw
16	24605286	Spring for 3
17	24610685	Actuating plate
18	25050091	Rec/pb connector

REF. NO.	PARTS NO.	DESCRIPTION
19	25050089	Erase connector
20	24610623	Terminal
22	24605277	Spring for 17
23	831130062	TPT+3x6mm, Screw
24	24602111	Gear
25	24610528	Trugger arm
26	24610529	Canceller arm
27	24610530	Recording arm
28	24610531	Flywheel holder
29	833126059	CT2.6x5, Screw
30	24602103	Flywheel
31	24602104	Flywheel gear
32	24610564	PSW2.5x4.7x0.25, Washer
33	24610567	2.4x8x0.3, Washer, Nylon
34	24610617	Pinch roller
35	24602127	Reel stand

TAMASO TAMASO